

2

1

Motorized Retractable Screen 7.125" Housing with Recessed Track

B

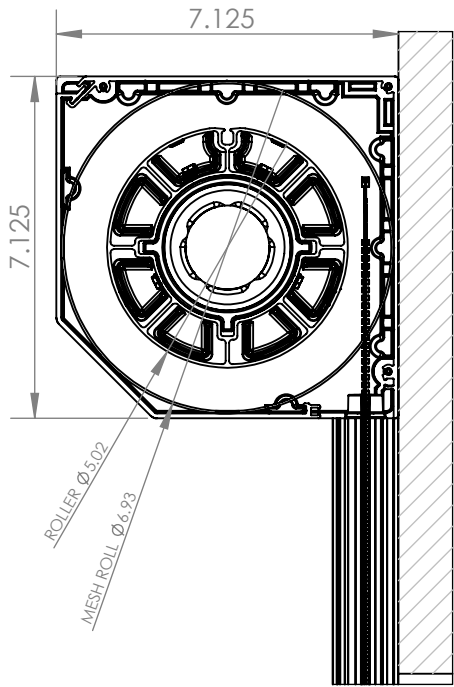

7.125" HOUSING ASSY
SECTION VIEW
SCALE 1:4

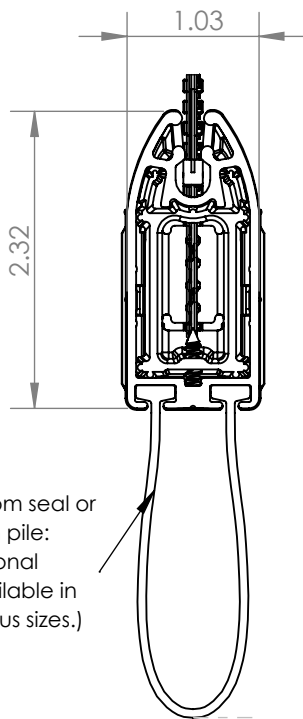

SLIDEBAR ASSY
SECTION VIEW
SCALE 1:1.5

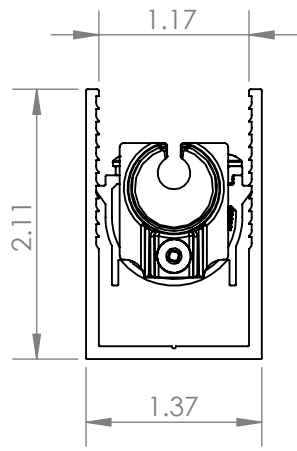

RECESSED TRACK ASSY
TOP VIEW
SCALE 1:1.5

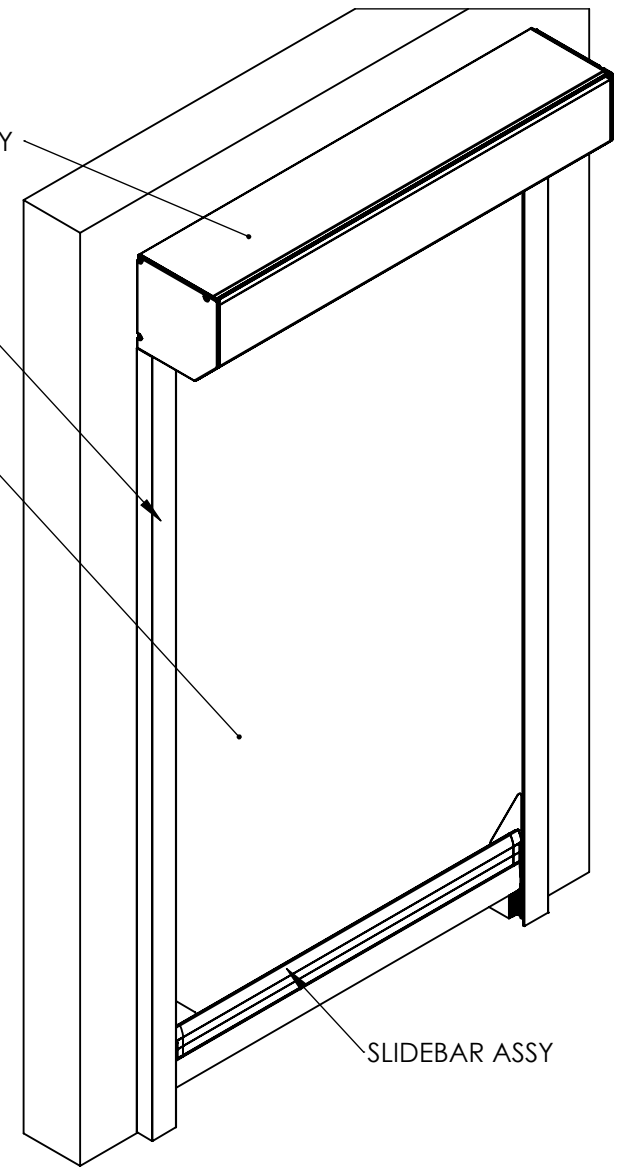

SCALE 1:12

B

A

Note:
Order includes housing assy, slidebar assy, track assys, and fabric only; all other parts to be ordered separately as required.

A

PROPRIETARY AND CONFIDENTIAL THE INFORMATION CONTAINED IN THIS DRAWING IS THE SOLE PROPERTY OF PHANTOM SCREENS. REPRODUCTION IN PART OR AS A WHOLE WITHOUT THE WRITTEN PERMISSION OF PHANTOM SCREENS IS PROHIBITED.		UNLESS OTHERWISE SPECIFIED: DIMENSIONS ARE IN INCHES. TOLERANCES: FRACTIONAL ± 1/32 ANGULAR ± 2 TWO PLACE DECIMAL ± .013" THREE PLACE DECIMAL ± .005"		STANDARD TOLERANCES APPLY UNLESS OTHERWISE SPECIFIED INTERPRET GEOMETRIC TOLERANCING PER: ASME Y14.5 THIRD ANGLE PROJECTION		DRAWN SA 2026-04-10 CHECKED PP 2026-04-10 ENG APPR. PP 2026-04-10 MFG APPR. Q.A.		TITLE: Mz2.0, 7.125 Housing, Recessed Track SIZE A DWG. NO. EPN512 SCALE: 1:12 WEIGHT:		REV 1 SHEET 1 OF 8	
		MATERIAL ASSY									

2

1

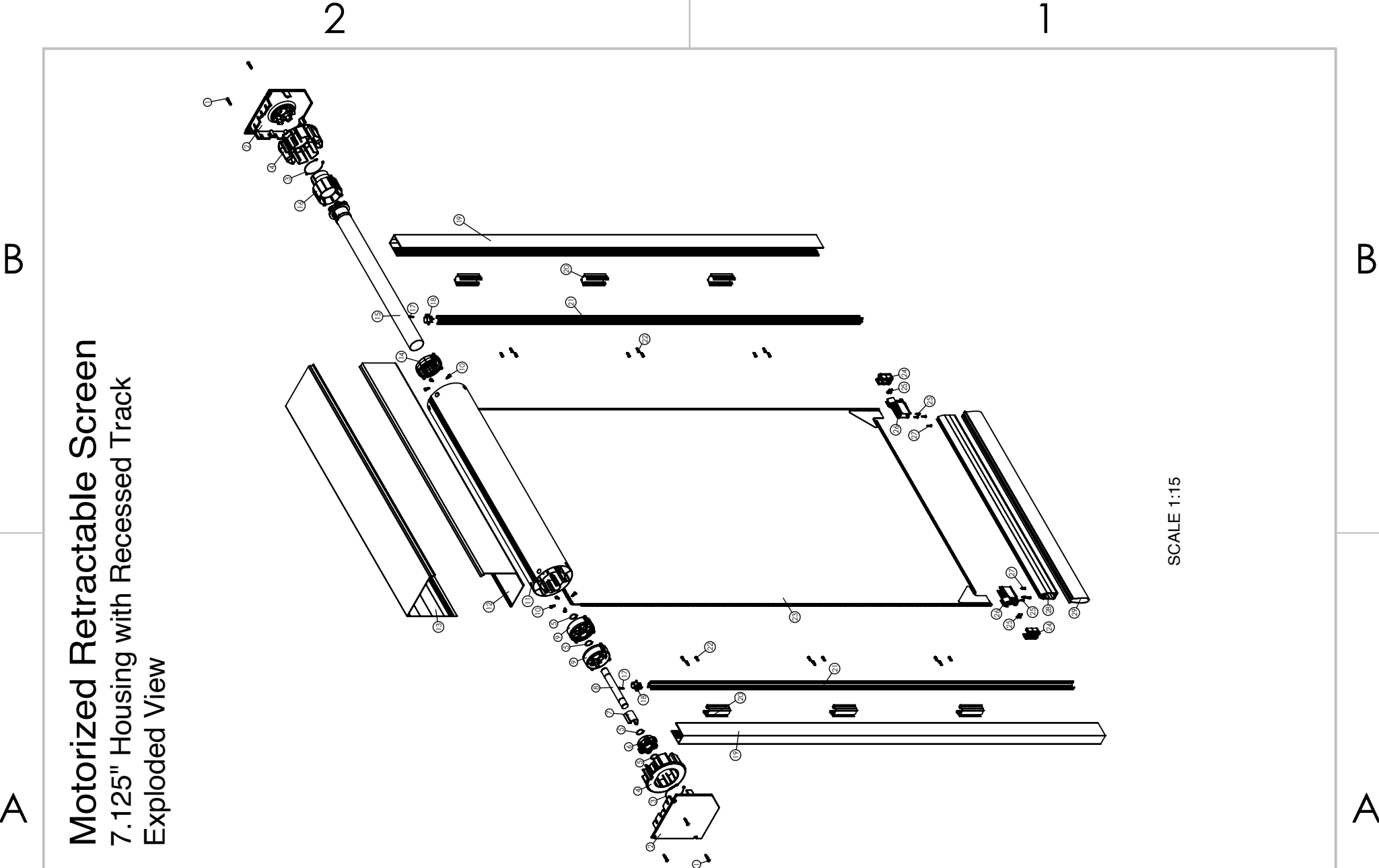

Motorized Retractable Screen
7.125" Housing with Recessed Track
Exploded View

SCALE 1:15

PROPRIETARY AND CONFIDENTIAL

THE INFORMATION CONTAINED IN THIS DRAWING IS THE SOLE PROPERTY OF PHANTOM SCREENS. REPRODUCTION IN PART OR AS A WHOLE WITHOUT THE WRITTEN PERMISSION OF PHANTOM SCREENS IS PROHIBITED.



PHANTOM
SCREENS

UNLESS OTHERWISE SPECIFIED:

DIMENSIONS ARE IN INCHES.
 TOLERANCES:
 FRACTIONAL $\pm 1/32$
 ANGULAR ± 2
 TWO PLACE DECIMAL $\pm .013$ "
 THREE PLACE DECIMAL $\pm .005$ "

STANDARD TOLERANCES APPLY UNLESS OTHERWISE SPECIFIED

INTERPRET GEOMETRIC TOLERANCING PER: ASME Y14.5
 THIRD ANGLE PROJECTION

MATERIAL
 ASSY

DRAWN	SA	2026-04-10
CHECKED	PP	2026-04-10
ENG APPR.	PP	2026-04-10
MFG APPR.		
Q.A.		

TITLE: Mz2.0, 7.125 Housing, Recessed Track		
SIZE	DWG. NO.	REV
A	EPN512	1
SCALE: 1:12	WEIGHT:	SHEET 2 OF 8

A

B

Motorized Retractable Screen 7.125" Housing with Recessed Track BOM Table

NO.	DESCRIPTION	QTY
1	71039 #8-1" Rounded Head Screw (Color matched)	6
2	68220 Mz2.0 End Cap 7.125"	2
3	46009 Mz Retaining Clip	2
4	46611 Mz Leveling Ring 5"	2
5	EPN214 External Retaining Ring	4
6	EPN3 Mz2.0 Pivot Head .75	1
7	EPN211 Mz Pivot Spacer	1
8	EPN7 Mz2.0 Pivot Shaft	1
9	EPN2 Mz2.0 Pivot Bearing	2
10	71021 #8-0.5" Hex Head Drilling Screw	8
11	46006 Mz2.0 Roller Bar 5"	1
12	EPN357 Housing Cover, 7.125"	1
13	EPN47120 Hsg, 1-Pc Back-Top, 7.125"	1
14	EPN4 Mz2.0 Motor Drive Ring	1
15	67235 Somfy Motor, 525A2 Maestria RTS	1
16	EPN5 Mz2.0 Motor Encoder Ring	1
17	90203A510 #6-5/8" Rounded Head Drilling Screw	2
18	68124 Motorized Entry Guide, Recessed	2
19	46002 Recessed U-Channel	2
20	46055 Recessed Track Clip	-
21	46056 Recessed track	2
22	90087A148 Rounded Head Thread-Cutting Screws for Metal	-
23	EPN437 Sure Fit Mesh	1
24	EPN161 Slidebar Endcap Cover	2
25	71027 #6-1/2" Rounded Head Screw	8
26	EPN160 Slidebar Endcap Main	2
27	71135 #6-5/8" Flat Head Screw	4
28	EPN199 Slidebar-w-Stopper	1
29	Brush pile or bottom gasket (available in various sizes)	1

1

2

A

B

PROPRIETARY AND CONFIDENTIAL

THE INFORMATION CONTAINED IN THIS DRAWING IS THE SOLE PROPERTY OF PHANTOM SCREENS. REPRODUCTION IN PART OR AS A WHOLE WITHOUT THE WRITTEN PERMISSION OF PHANTOM SCREENS IS PROHIBITED.



PHANTOM
SCREENS

UNLESS OTHERWISE SPECIFIED:

DIMENSIONS ARE IN INCHES.
TOLERANCES:
FRACTIONAL $\pm 1/32$
ANGULAR ± 2
TWO PLACE DECIMAL $\pm .013$ "
THREE PLACE DECIMAL $\pm .005$ "

STANDARD TOLERANCES APPLY UNLESS OTHERWISE SPECIFIED

INTERPRET GEOMETRIC TOLERANCING PER: ASME Y14.5
THIRD ANGLE PROJECTION

MATERIAL

ASSY

DRAWN

CHECKED

ENG APPR.

MFG APPR.

Q.A.

SA

PP

PP

2026-04-10

2026-04-10

2026-04-10

TITLE: Mz2.0, 7.125 Housing, Recessed Track

SIZE

A

DWG. NO.

EPN512

REV

1

SCALE: 1:12

WEIGHT:

SHEET 3 OF 8

1

2

DOCUMENT NO. XXXXX-XX-XXX

2

1

Motorized Retractable Screen

7.125" Housing with Recessed Track

Housing and Tracks: In-Jamb

Tracks Mounted on Back (*)

B

B

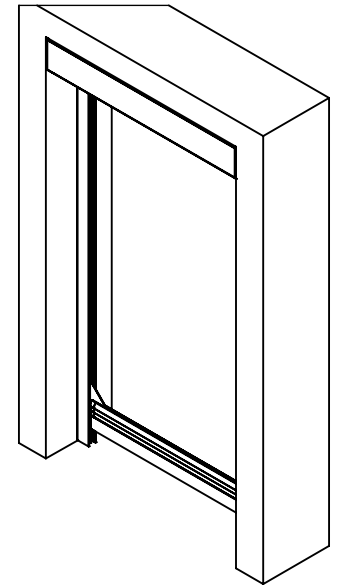
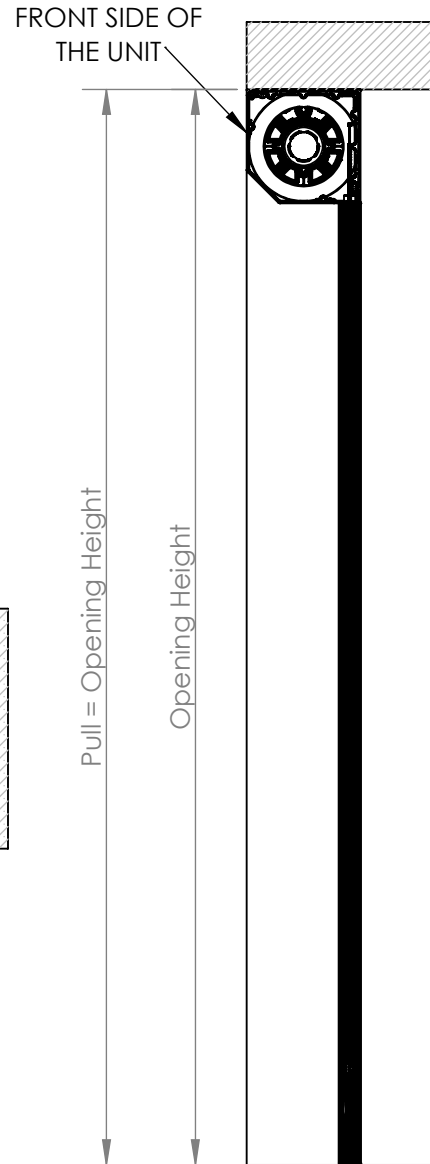
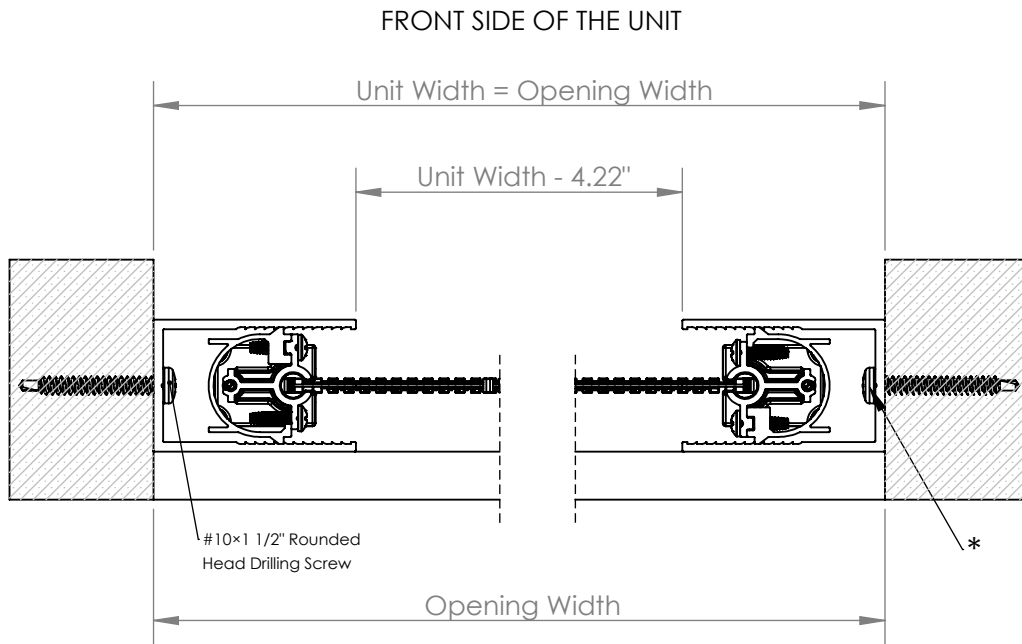

SCALE 1:25

A

A

Note:

- Screen unit height can be reduced by cutting the tracks on site.
- Screen unit width is fixed and must be accurate when ordering.

PROPRIETARY AND CONFIDENTIAL

THE INFORMATION CONTAINED IN THIS DRAWING IS THE SOLE PROPERTY OF PHANTOM SCREENS. REPRODUCTION IN PART OR AS A WHOLE WITHOUT THE WRITTEN PERMISSION OF PHANTOM SCREENS IS PROHIBITED.



UNLESS OTHERWISE SPECIFIED:

DIMENSIONS ARE IN INCHES.
 TOLERANCES:
 FRACTIONAL ± 1/32
 ANGULAR ± 2
 TWO PLACE DECIMAL ± .013"
 THREE PLACE DECIMAL ± .005"

STANDARD TOLERANCES APPLY UNLESS OTHERWISE SPECIFIED

INTERPRET GEOMETRIC TOLERANCING PER: ASME Y14.5
 THIRD ANGLE PROJECTION

MATERIAL

ASSY

DRAWN

SA

2026-04-10

CHECKED

PP

2026-04-10

ENG APPR.

PP

2026-04-10

MFG APPR.

Q.A.

TITLE: Mz2.0, 7.125 Housing, Recessed Track

SIZE

DWG. NO.

REV

A

EPN512

1

SCALE: 1:12

WEIGHT:

SHEET 4 OF 8

2

1

DOCUMENT NO. XXXX-XX-XXX

Motorized Retractable Screen

7.125" Housing with Recessed Track
 Housing and Tracks: In-Jamb
 U-Guard Used for Adjustment on Unparallel Posts
 Tracks Mounted on Back (*)

B

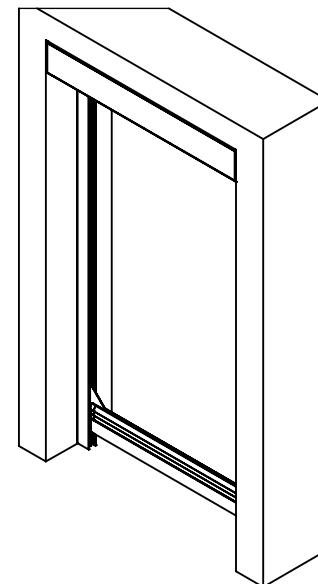
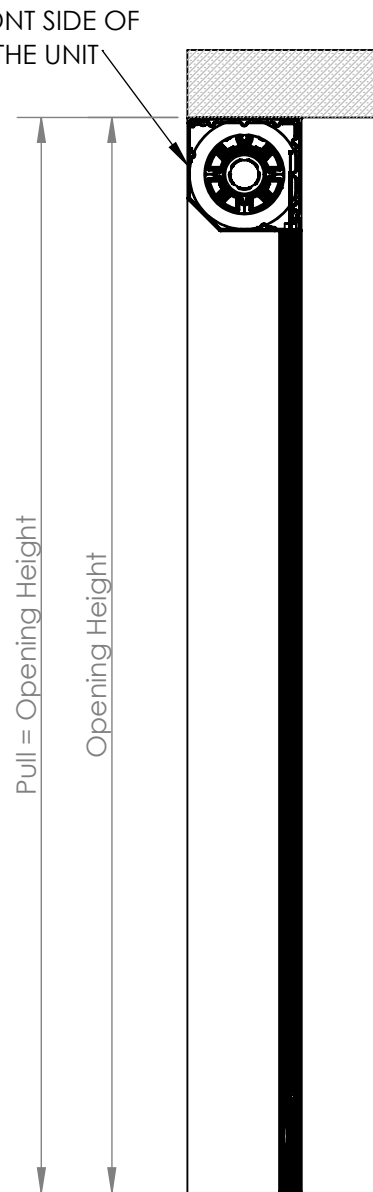
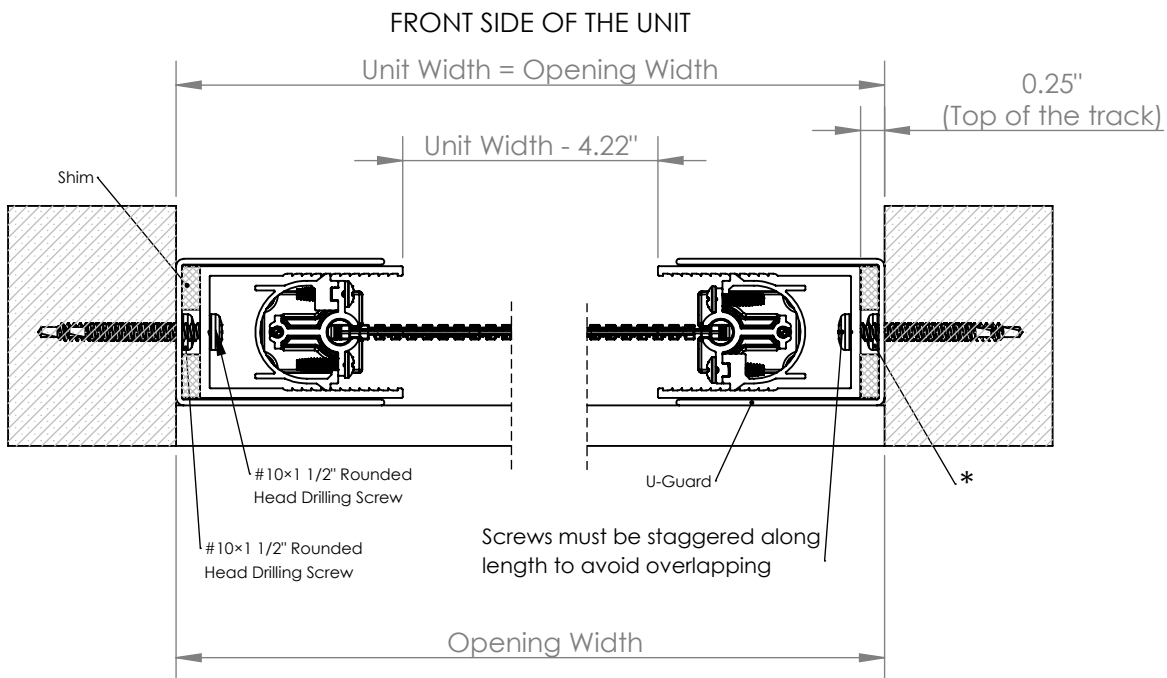

B

A

- Note:**
- Screen unit height can be reduced by cutting the tracks on site.
 - Screen unit width is fixed and must be accurate when ordering.

A

PROPRIETARY AND CONFIDENTIAL THE INFORMATION CONTAINED IN THIS DRAWING IS THE SOLE PROPERTY OF PHANTOM SCREENS. REPRODUCTION IN PART OR AS A WHOLE WITHOUT THE WRITTEN PERMISSION OF PHANTOM SCREENS IS PROHIBITED.		UNLESS OTHERWISE SPECIFIED: DIMENSIONS ARE IN INCHES. FRACTIONAL ± 1/32 ANGULAR ± 2 TWO PLACE DECIMAL ± .013" THREE PLACE DECIMAL ± .005"		STANDARD TOLERANCES APPLY UNLESS OTHERWISE SPECIFIED INTERPRET GEOMETRIC TOLERANCING PER: ASME Y14.5 THIRD ANGLE PROJECTION		DRAWN SA 2026-04-10 CHECKED PP 2026-04-10 ENG APPR. PP 2026-04-10 MFG APPR. Q.A.		TITLE: Mz2.0, 7.125 Housing, Recessed Track SIZE A DWG. NO. EPN512 SCALE: 1:12 WEIGHT:		REV 1 SHEET 5 OF 8	
		MATERIAL ASSY									

Motorized Retractable Screen

7.125" Housing with Recessed Track

Housing and Tracks: In-Jamb

U-Guard Used for Adjustment on Unparallel Posts

Tracks Mounted on Side (*)

B

B

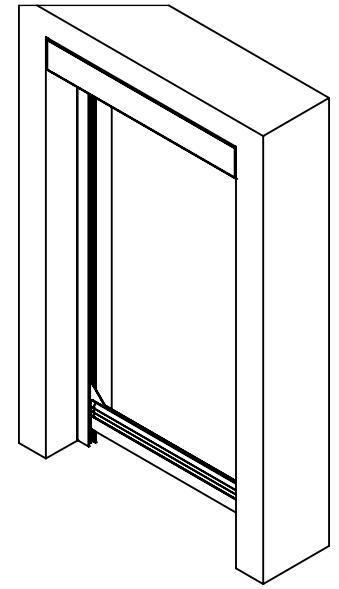
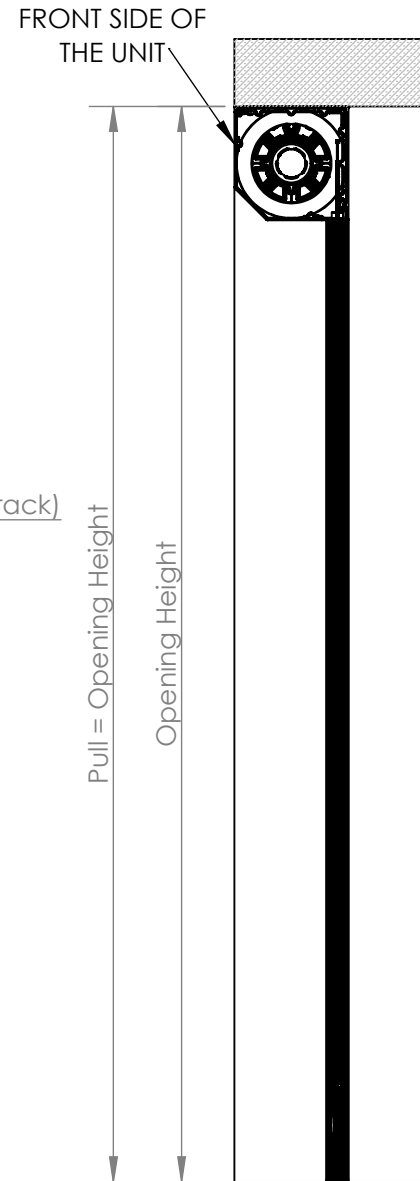
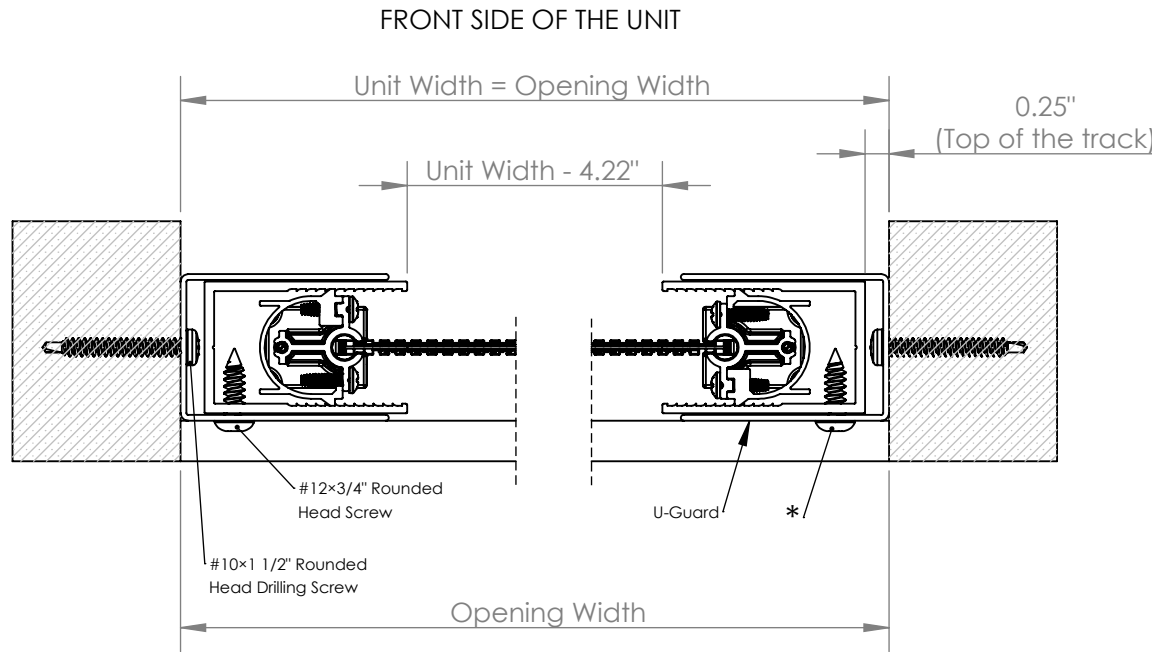

A

A

Note:

- Screen unit height can be reduced by cutting the tracks on site.
- Screen unit width is fixed and must be accurate when ordering.

PROPRIETARY AND CONFIDENTIAL

THE INFORMATION CONTAINED IN THIS DRAWING IS THE SOLE PROPERTY OF PHANTOM SCREENS. REPRODUCTION IN PART OR AS A WHOLE WITHOUT THE WRITTEN PERMISSION OF PHANTOM SCREENS IS PROHIBITED.



UNLESS OTHERWISE SPECIFIED:

DIMENSIONS ARE IN INCHES.
 TOLERANCES:
 FRACTIONAL ± 1/32
 ANGULAR ± 2
 TWO PLACE DECIMAL ± .013"
 THREE PLACE DECIMAL ± .005"

STANDARD TOLERANCES APPLY UNLESS OTHERWISE SPECIFIED

INTERPRET GEOMETRIC TOLERANCING PER: ASME Y14.5
 THIRD ANGLE PROJECTION

MATERIAL

ASSY

DRAWN	SA	2026-04-10
CHECKED	PP	2026-04-10
ENG APPR.	PP	2026-04-10
MFG APPR.		
Q.A.		

TITLE: Mz2.0, 7.125 Housing, Recessed Track

SIZE	DWG. NO.	REV
A	EPN512	1

SCALE: 1:12	WEIGHT:	SHEET 6 OF 8
-------------	---------	--------------

Motorized Retractable Screen

7.125" Housing with Recessed Track

Housing and Tracks: In-Jamb

L-Flap Used for Adjustment on Unparallel Posts

Tracks Mounted on Side (*)

L-Flap Mounted behind the Track (**)

B

B

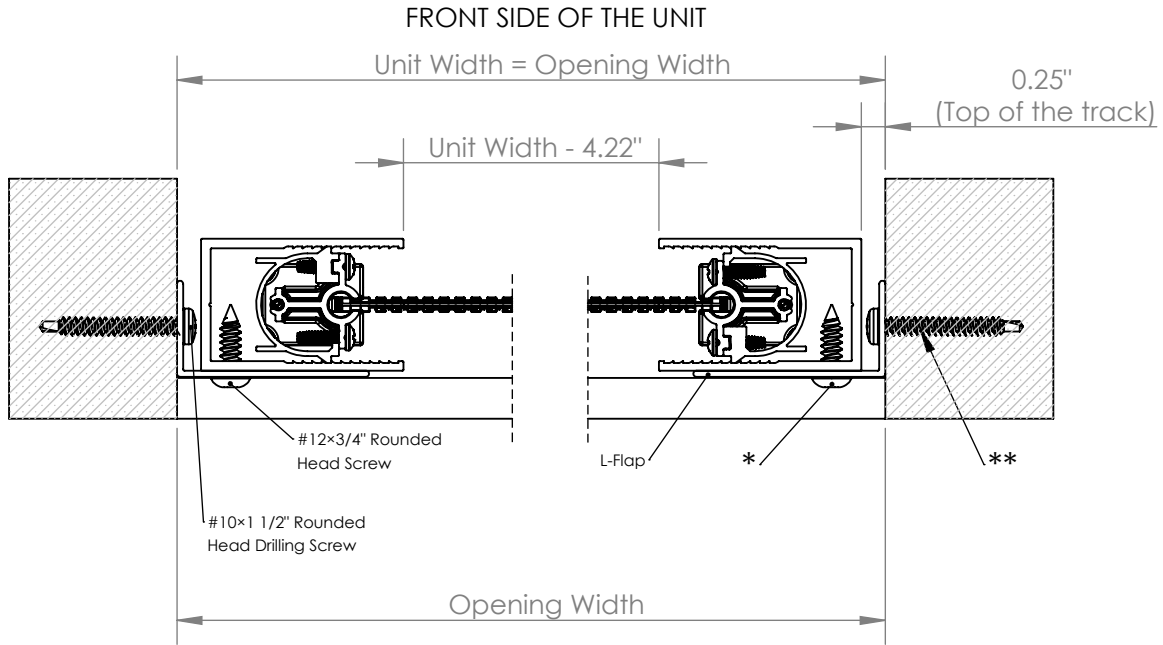

Note:

- Screen unit height can be reduced by cutting the tracks on site.
- Screen unit width is fixed and must be accurate when ordering.

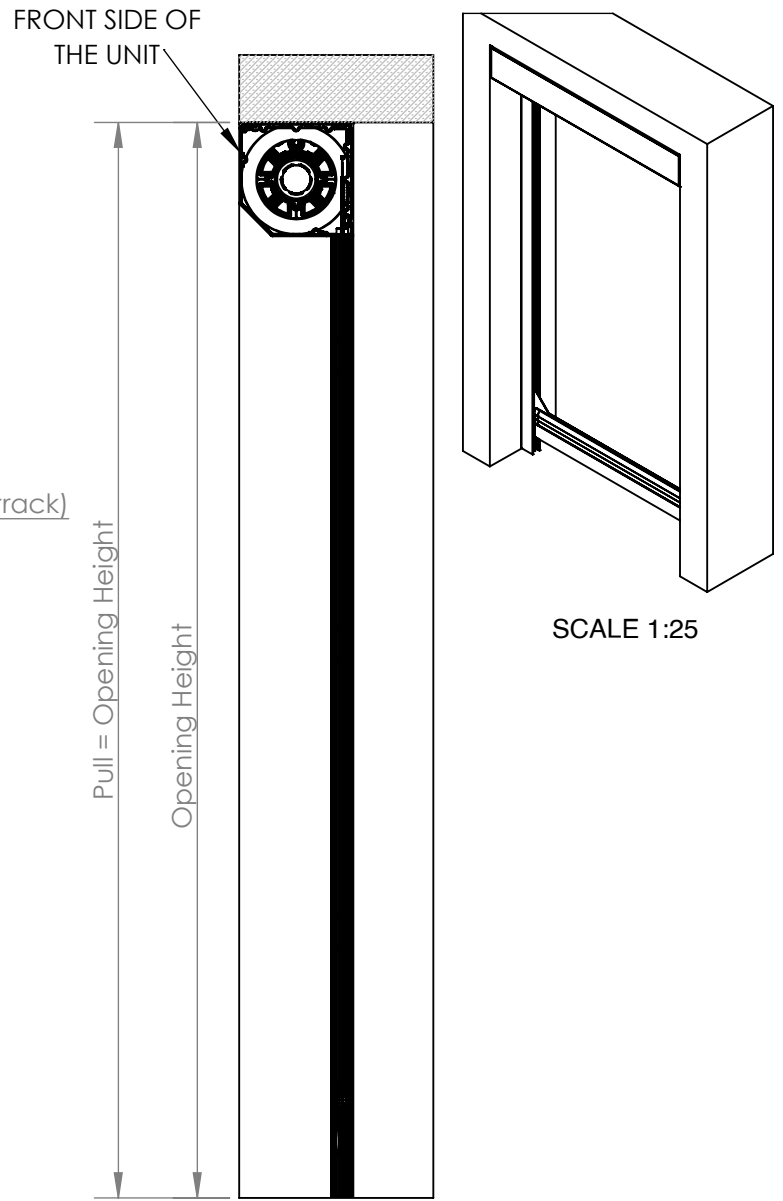

A

A

PROPRIETARY AND CONFIDENTIAL THE INFORMATION CONTAINED IN THIS DRAWING IS THE SOLE PROPERTY OF PHANTOM SCREENS. REPRODUCTION IN PART OR AS A WHOLE WITHOUT THE WRITTEN PERMISSION OF PHANTOM SCREENS IS PROHIBITED.		UNLESS OTHERWISE SPECIFIED: DIMENSIONS ARE IN INCHES. TOLERANCES: FRACTIONAL ± 1/32 ANGULAR ± 2 TWO PLACE DECIMAL ± .013" THREE PLACE DECIMAL ± .005"		STANDARD TOLERANCES APPLY UNLESS OTHERWISE SPECIFIED INTERPRET GEOMETRIC TOLERANCING PER: ASME Y14.5 THIRD ANGLE PROJECTION		DRAWN SA 2026-04-10 CHECKED PP 2026-04-10 ENG APPR. PP 2026-04-10 MFG APPR. Q.A.		TITLE: Mz2.0, 7.125 Housing, Recessed Track SIZE A DWG. NO. EPN512 SCALE: 1:12 WEIGHT:		REV 1 SHEET 7 OF 8	
		MATERIAL ASSY									

Motorized Retractable Screen

7.125" Housing with Recessed Track

Housing and Tracks: In-Jamb

L-Flap Used for Adjustment on Unparallel Posts

Tracks Mounted on Side (*)

L-Flap Mounted on the Side of the Track (**)

B

B

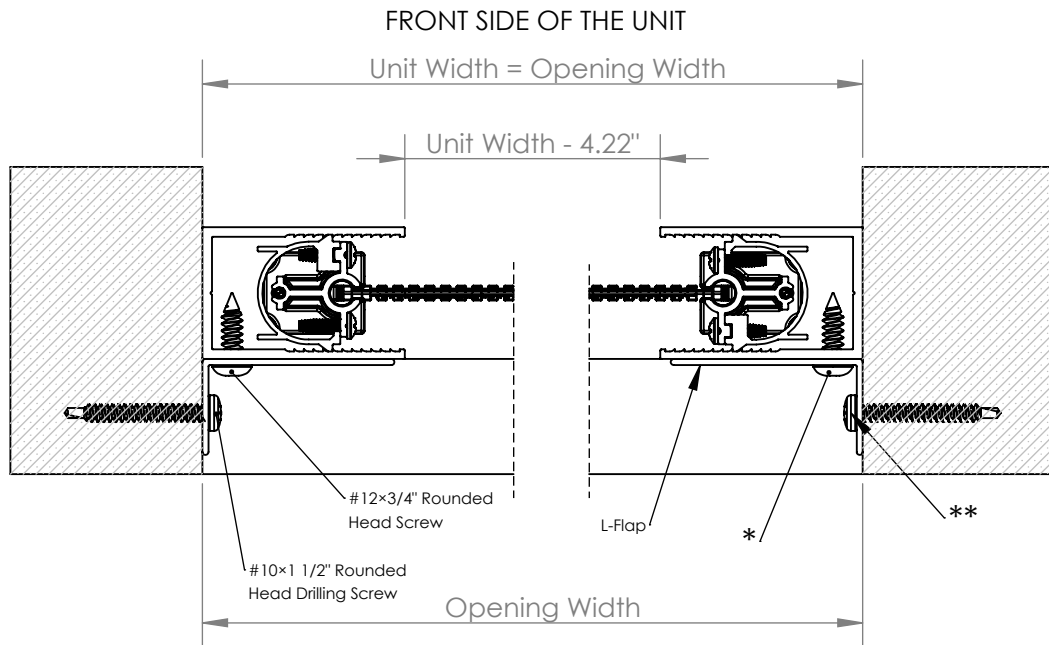

Note:

- Screen unit height can be reduced by cutting the tracks on site.
- Screen unit width is fixed and must be accurate when ordering.

FRONT SIDE OF THE UNIT

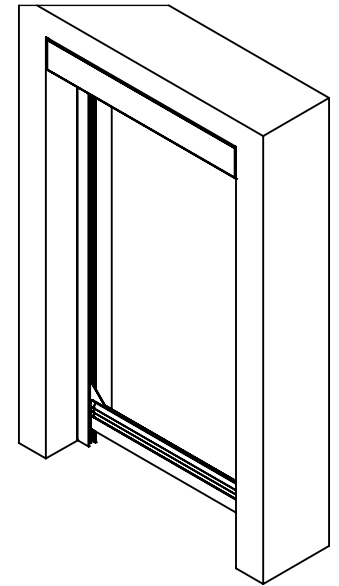
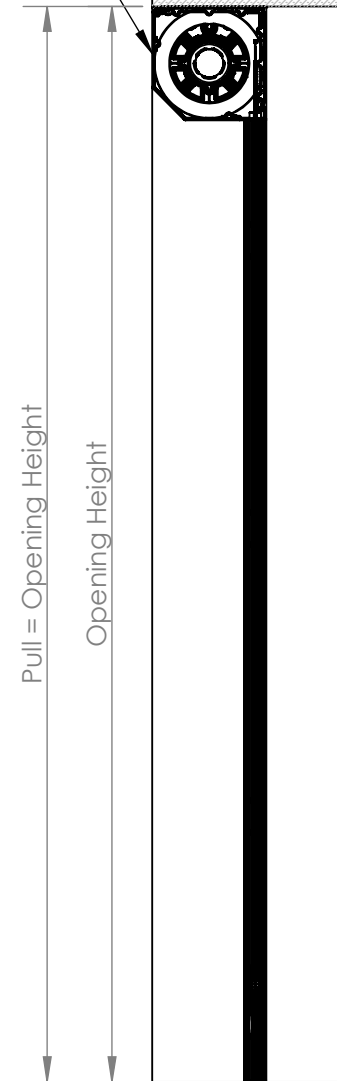

SCALE 1:25

A

A

PROPRIETARY AND CONFIDENTIAL

THE INFORMATION CONTAINED IN THIS DRAWING IS THE SOLE PROPERTY OF PHANTOM SCREENS. REPRODUCTION IN PART OR AS A WHOLE WITHOUT THE WRITTEN PERMISSION OF PHANTOM SCREENS IS PROHIBITED.



UNLESS OTHERWISE SPECIFIED:

DIMENSIONS ARE IN INCHES.
 TOLERANCES:
 FRACTIONAL ± 1/32
 ANGULAR ± 2
 TWO PLACE DECIMAL ± .013"
 THREE PLACE DECIMAL ± .005"

STANDARD TOLERANCES APPLY UNLESS OTHERWISE SPECIFIED

INTERPRET GEOMETRIC TOLERANCING PER: ASME Y14.5
 THIRD ANGLE PROJECTION

MATERIAL

ASSY

DRAWN

SA

2026-04-10

CHECKED

PP

2026-04-10

ENG APPR.

PP

2026-04-10

MFG APPR.

Q.A.

TITLE: Mz2.0, 7.125 Housing, Recessed Track

SIZE

DWG. NO.

REV

A

EPN512

1

SCALE: 1:12

WEIGHT:

SHEET 8 OF 8