

Motorized Retractable Screen

5" Recessed Roller with Sure Fit Track

B

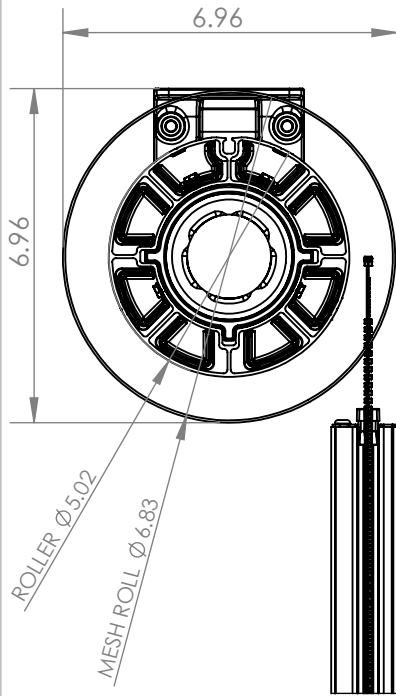

5" RECESSED ROLLER ASSY
SECTION VIEW
SCALE 1:4

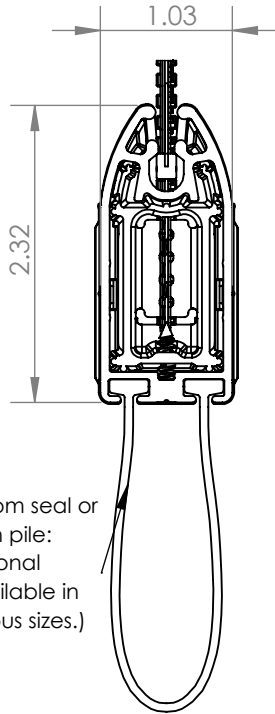

SLIDEBAR ASSY
SECTION VIEW
SCALE 1:1.5

Bottom seal or
Brush pile:
Optional
(Available in
various sizes.)

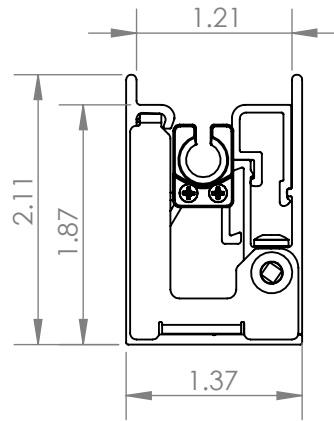

SURE FIT TRACK ASSY
TOP VIEW
SCALE 1:1.5

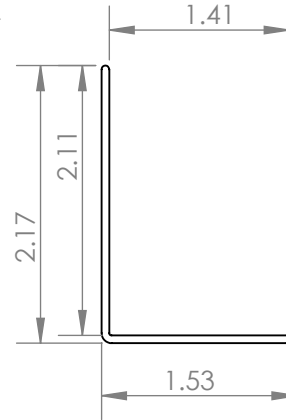

U-GUARD
TOP VIEW
SCALE 1:1.5

1

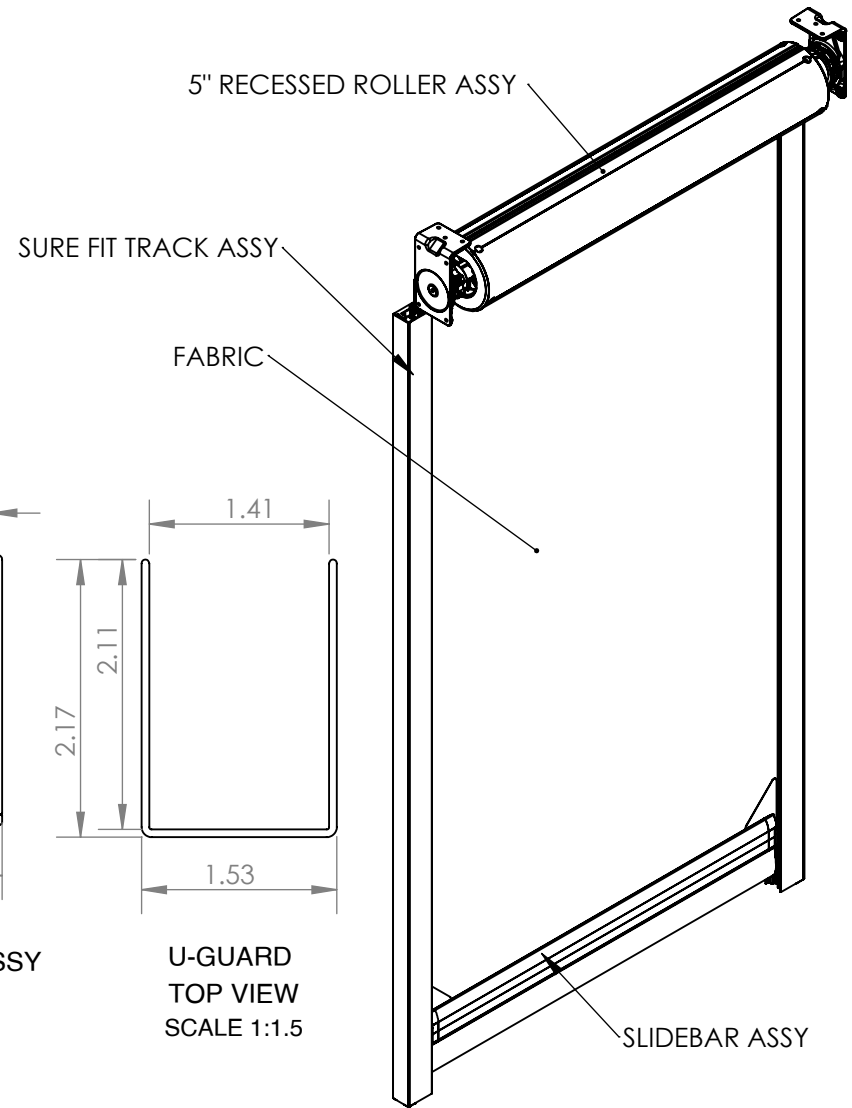

SCALE 1:12

B

A

Note:

Order includes roller assy, slider bar assy, track assys, and fabric only; all other parts to be ordered separately as required.

PROPRIETARY AND CONFIDENTIAL

THE INFORMATION CONTAINED IN THIS DRAWING IS THE SOLE PROPERTY OF PHANTOM SCREENS. REPRODUCTION IN PART OR AS A WHOLE WITHOUT THE WRITTEN PERMISSION OF PHANTOM SCREENS IS PROHIBITED.



UNLESS OTHERWISE SPECIFIED:

DIMENSIONS ARE IN INCHES.
TOLERANCES:
FRACTIONAL ± 1/32
ANGULAR ± 2
TWO PLACE DECIMAL ± .013"
THREE PLACE DECIMAL ± .005"

STANDARD TOLERANCES APPLY UNLESS OTHERWISE SPECIFIED

INTERPRET GEOMETRIC TOLERANCING PER: ASME Y14.5
THIRD ANGLE PROJECTION

MATERIAL
ASSY

DRAWN	SA	2025-12-15
CHECKED	PP	2025-12-15
ENG APPR.	PP	2025-12-15
MFG APPR.		
Q.A.		

TITLE: Mz2.0, 5" Recessed Roller, Sure Fit Track

SIZE	DWG. NO.	REV
A	EPN450	5

SCALE: 1:12	WEIGHT:	SHEET 1 OF 16
-------------	---------	---------------

2

1

DOCUMENT NO. XXXXX-XX-XXX

2

1

B

B

**Motorized Retractable Screen
5" Recessed Roller with Sure Fit Track
Exploded View**

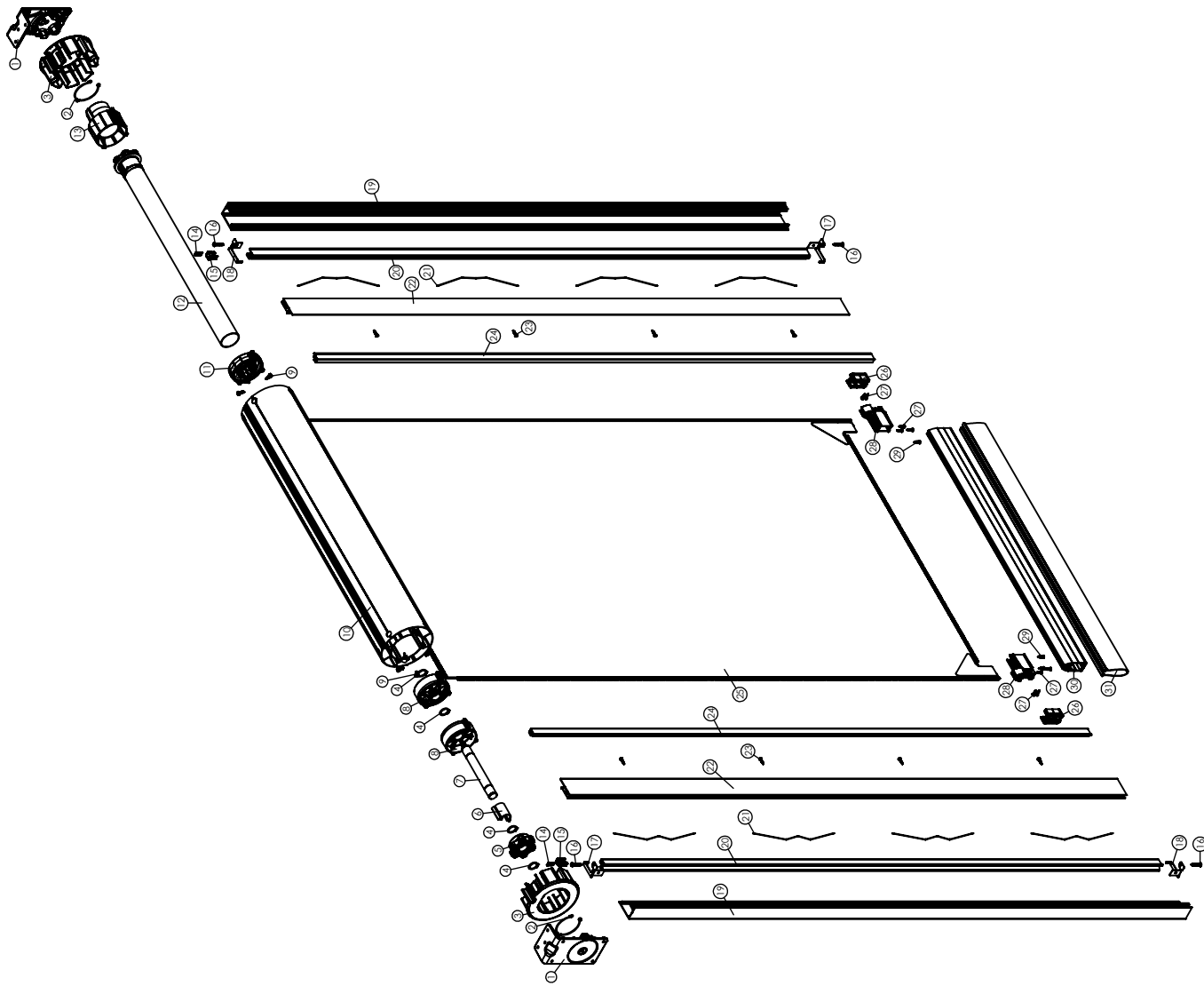

SCALE 1:15

A

A

PROPRIETARY AND CONFIDENTIAL

THE INFORMATION CONTAINED IN THIS DRAWING IS THE SOLE PROPERTY OF PHANTOM SCREENS. REPRODUCTION IN PART OR AS A WHOLE WITHOUT THE WRITTEN PERMISSION OF PHANTOM SCREENS IS PROHIBITED.



UNLESS OTHERWISE SPECIFIED:

DIMENSIONS ARE IN INCHES.
TOLERANCES:
FRACTIONAL $\pm 1/32$
ANGULAR ± 2
TWO PLACE DECIMAL $\pm .013$ "
THREE PLACE DECIMAL $\pm .005$ "

STANDARD TOLERANCES APPLY UNLESS OTHERWISE SPECIFIED

INTERPRET GEOMETRIC TOLERANCING PER: ASME Y14.5
THIRD ANGLE PROJECTION

MATERIAL

ASSY

DRAWN

SA

2025-12-15

CHECKED

PP

2025-12-15

ENG APPR.

PP

2025-12-15

MFG APPR.

Q.A.

TITLE: Mz2.0, 5" Recessed Roller, Sure Fit Track

SIZE

DWG. NO.

REV

A

EPN450

5

SCALE: 1:12

WEIGHT:

SHEET 2 OF 16

2

1

DOCUMENT NO. XXXXX-XX-XXX

A

B

Motorized Retractable Screen 5" Recessed Roller with Sure Fit Track BOM Table

NO.	DESCRIPTION	QTY
1	48201 Mtz 2.0 Recessed Bracket, 5in	2
2	46009 Mz Retaining Clip	2
3	46611 Mz Leveling Ring 5"	2
4	EPN214 External Retaining Ring	4
5	EPN3 Mz2.0 Pivot Head .75	1
6	EPN211 Mz Pivot Spacer	1
7	EPN7 Mz2.0 Pivot Shaft	1
8	EPN2 Mz2.0 Pivot Bearing	2
9	71021 #8-0.5" Hex Head Drilling Screw	8
10	46006 Mz2.0 Roller Bar 5"	1
11	EPN4 Mz2.0 Motor Drive Ring	1
12	67235 Somfy Motor, 525A2 Maestria RTS	1
13	EPN5 Mz2.0 Motor Encoder Ring	1
14	EPN314 # 1-5/8" Rounded Head Screw	4
15	68155 Sure Fit Entry Guide	2
16	71039 # 10-1" Rounded Head Screw (Unfinished)	4
17	46854 Sure Fit Lift Stop Left	2
18	46898 Sure Fit Lift Stop Right	2
19	46909 Sure Fit U-Channel	2
20	46844 Sure Fit Inner Track	2
21	46045 Sure Fit Spring	-
22	47014 Sure Fit U-Channel Side	2
23	EPN312 # 6-5/8" Rounded Head Screw	-
24	47024 Sure Fit Cover	2
25	EPN437 Sure Fit Mesh	1
26	EPN161 Slidebar Endcap Cover	2
27	71027 #6-1/2" Rounded Head Screw	8
28	EPN160 Slidebar Endcap Main	2
29	71135 #6-5/8" Flat Head Screw	4
30	EPN199 Slidebar-w-Stopper	1
31	Brush pile or bottom gasket (available in various sizes)	1

A

B

PROPRIETARY AND CONFIDENTIAL

THE INFORMATION CONTAINED IN THIS DRAWING IS THE SOLE PROPERTY OF PHANTOM SCREENS. REPRODUCTION IN PART OR AS A WHOLE WITHOUT THE WRITTEN PERMISSION OF PHANTOM SCREENS IS PROHIBITED.



UNLESS OTHERWISE SPECIFIED:

DIMENSIONS ARE IN INCHES.
TOLERANCES:
FRACTIONAL $\pm 1/32$
ANGULAR ± 2
TWO PLACE DECIMAL $\pm .013$ "
THREE PLACE DECIMAL $\pm .005$ "

STANDARD TOLERANCES APPLY UNLESS OTHERWISE SPECIFIED

INTERPRET GEOMETRIC TOLERANCING PER: ASME Y14.5
THIRD ANGLE PROJECTION

MATERIAL

ASSY

DRAWN

SA

2025-12-15

CHECKED

PP

2025-12-15

ENG APPR.

PP

2025-12-15

MFG APPR.

Q.A.

TITLE: Mz2.0, 5" Recessed Roller, Sure Fit Track

SIZE

A

DWG. NO.

EPN450

REV

5

SCALE: 1:12

WEIGHT:

SHEET 3 OF 16

2

1

DOCUMENT NO. XXXXX-XX-XXX

Motorized Retractable Screen

5" Recessed Roller with 5" Cavity Cover

Minimum Cavity Size

B

B

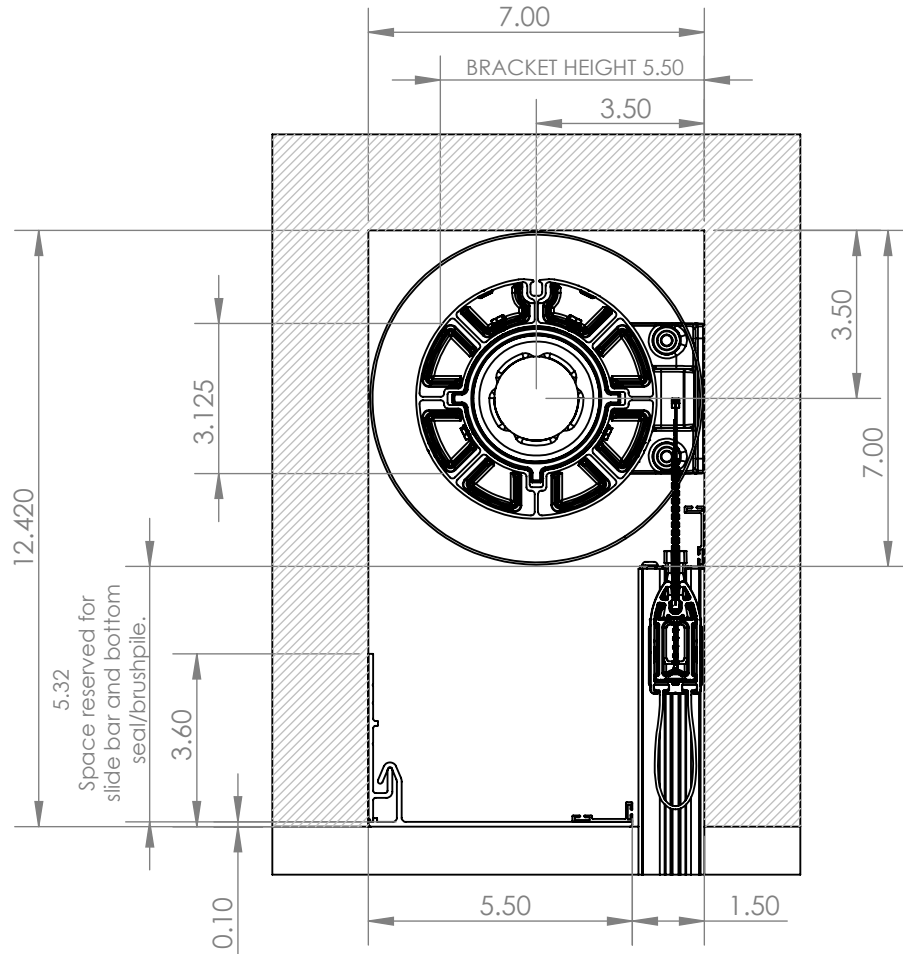

HORIZONTALLY MOUNTED
BRACKETS

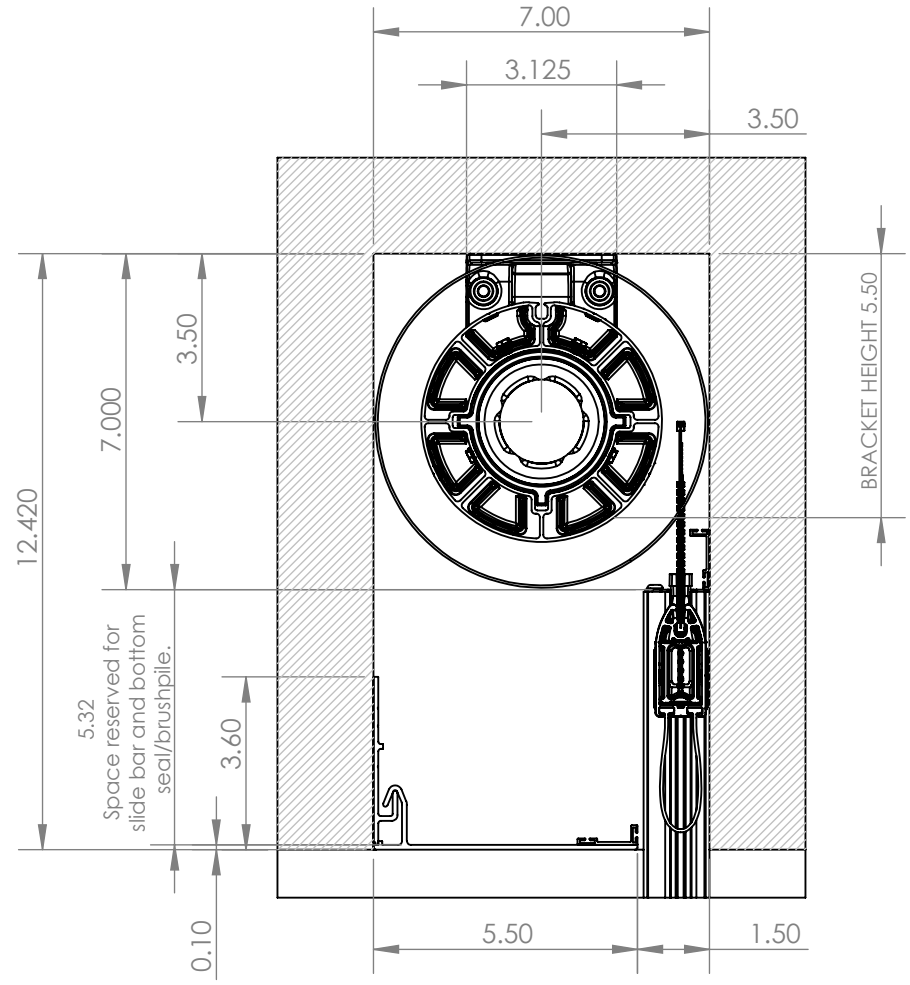

VERTICALLY MOUNTED
BRACKETS

A

A

PROPRIETARY AND CONFIDENTIAL

THE INFORMATION CONTAINED IN THIS DRAWING IS THE SOLE PROPERTY OF PHANTOM SCREENS. REPRODUCTION IN PART OR AS A WHOLE WITHOUT THE WRITTEN PERMISSION OF PHANTOM SCREENS IS PROHIBITED.



UNLESS OTHERWISE SPECIFIED:

DIMENSIONS ARE IN INCHES.
TOLERANCES:
FRACTIONAL $\pm 1/32$
ANGULAR ± 2
TWO PLACE DECIMAL $\pm .013$ "
THREE PLACE DECIMAL $\pm .005$ "

STANDARD TOLERANCES APPLY UNLESS OTHERWISE SPECIFIED

INTERPRET GEOMETRIC TOLERANCING PER: ASME Y14.5
THIRD ANGLE PROJECTION

MATERIAL

ASSY

DRAWN

SA

2025-12-15

CHECKED

PP

2025-12-15

ENG APPR.

PP

2025-12-15

MFG APPR.

Q.A.

TITLE: Mz2.0, 5" Recessed Roller, Sure Fit Track

SIZE

DWG. NO.

REV

A

EPN450

5

SCALE: 1:12

WEIGHT:

SHEET 4 OF 16

2

1

DOCUMENT NO. XXXXX-XX-XXX

Motorized Retractable Screen

5" Recessed Roller with 5" Cavity Cover

Recommended Cavity Size

B

B

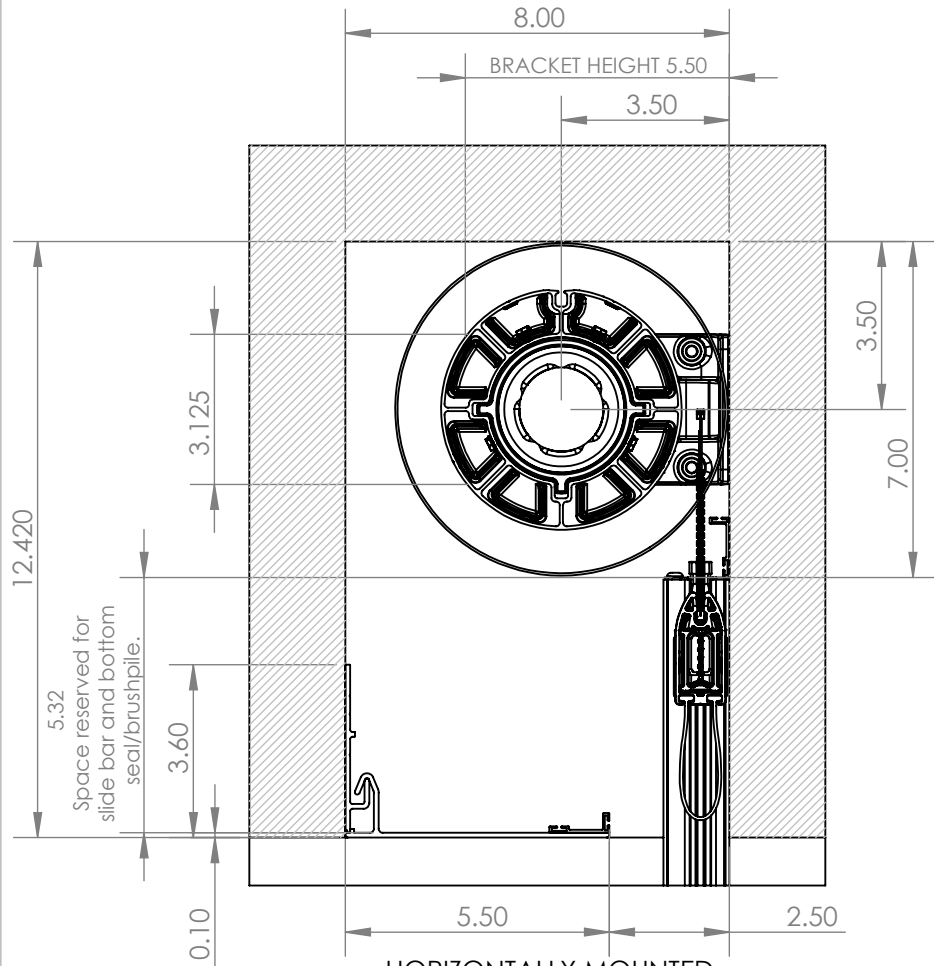

HORIZONTALLY MOUNTED BRACKETS

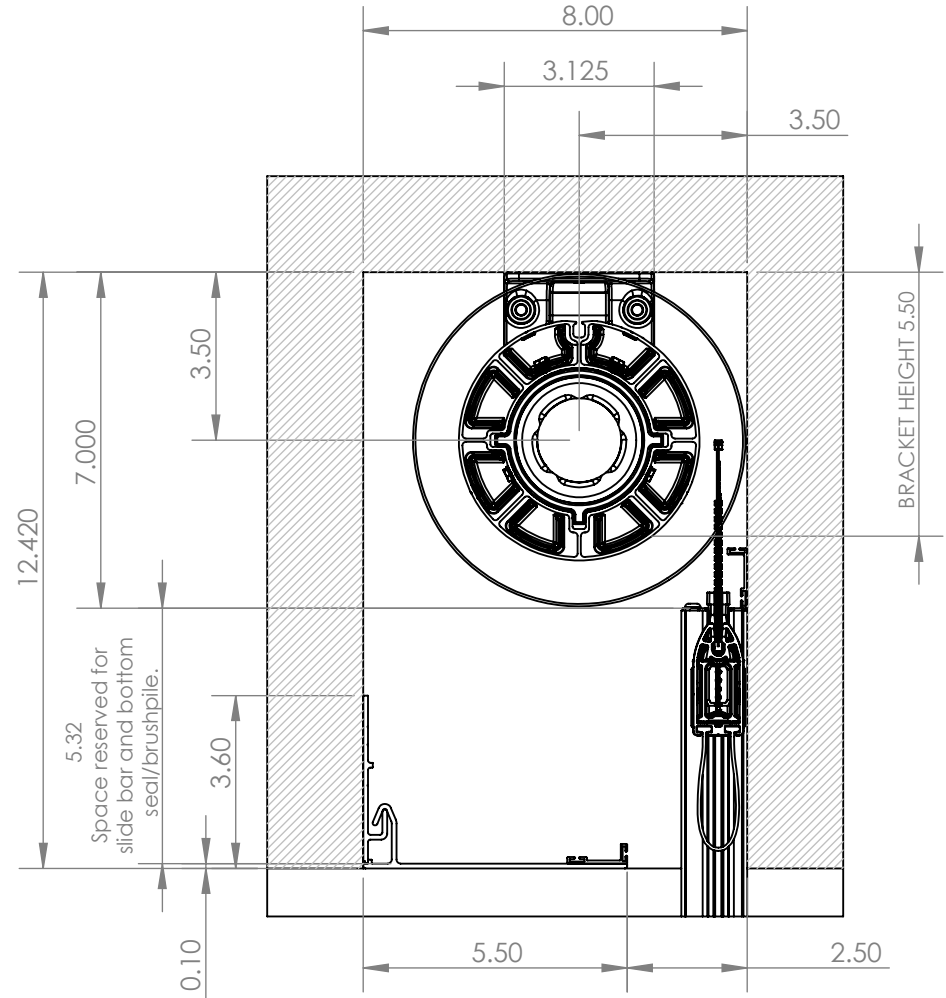

VERTICALLY MOUNTED BRACKETS

A

A

PROPRIETARY AND CONFIDENTIAL

THE INFORMATION CONTAINED IN THIS DRAWING IS THE SOLE PROPERTY OF PHANTOM SCREENS. REPRODUCTION IN PART OR AS A WHOLE WITHOUT THE WRITTEN PERMISSION OF PHANTOM SCREENS IS PROHIBITED.



UNLESS OTHERWISE SPECIFIED:

DIMENSIONS ARE IN INCHES.
 TOLERANCES:
 FRACTIONAL $\pm 1/32$
 ANGULAR ± 2
 TWO PLACE DECIMAL $\pm .013$ "
 THREE PLACE DECIMAL $\pm .005$ "

STANDARD TOLERANCES APPLY UNLESS OTHERWISE SPECIFIED

INTERPRET GEOMETRIC TOLERANCING PER: ASME Y14.5
 THIRD ANGLE PROJECTION

MATERIAL

ASSY

DRAWN	SA	2025-12-15
CHECKED	PP	2025-12-15
ENG APPR.	PP	2025-12-15
MFG APPR.		
Q.A.		

TITLE: Mz2.0, 5" Recessed Roller, Sure Fit Track

SIZE	DWG. NO.	REV
A	EPN450	5

SCALE: 1:12	WEIGHT:	SHEET 5 OF 16
-------------	---------	---------------

2

1

DOCUMENT NO. XXXX-XX-XXX

2

1

Motorized Retractable Screen

5" Recessed Roller with Sure Fit Track

Track Surface-Positioned

Tracks Side Mounted (*)

B

B

FRONT SIDE OF THE UNIT

Space reserved for slide bar and bottom seal/brushpile on top, clear of the opening for maximum view.

FRONT SIDE OF THE UNIT

Unit Width = Opening Width + 4.22"

Unit Width - 4.22"

Opening Width

#10x1 1/2" Rounded Head Drilling Screw

*

Note:

- Screen unit height can be reduced by cutting the tracks on site.
- Screen unit width is fixed and must be accurate when ordering.

Opening Height

Pull = Opening Height + 12.320"

A

PROPRIETARY AND CONFIDENTIAL

THE INFORMATION CONTAINED IN THIS DRAWING IS THE SOLE PROPERTY OF PHANTOM SCREENS. REPRODUCTION IN PART OR AS A WHOLE WITHOUT THE WRITTEN PERMISSION OF PHANTOM SCREENS IS PROHIBITED.



UNLESS OTHERWISE SPECIFIED:

DIMENSIONS ARE IN INCHES.
 TOLERANCES:
 FRACTIONAL ± 1/32
 ANGULAR ± 2
 TWO PLACE DECIMAL ± .013"
 THREE PLACE DECIMAL ± .005"

STANDARD TOLERANCES APPLY UNLESS OTHERWISE SPECIFIED

INTERPRET GEOMETRIC TOLERANCING PER: ASME Y14.5
 THIRD ANGLE PROJECTION

MATERIAL

ASSY

DRAWN

SA

2025-12-15

CHECKED

PP

2025-12-15

ENG APPR.

PP

2025-12-15

MFG APPR.

Q.A.

TITLE: Mz2.0, 5" Recessed Roller, Sure Fit Track

SIZE

DWG. NO.

REV

A

EPN450

5

SCALE: 1:12

WEIGHT:

SHEET 6 OF 16

2

1

DOCUMENT NO. XXXXX-XX-XXX

2

1

Motorized Retractable Screen

5" Recessed Roller with Sure Fit Track

Track In-Jamb Positioned

Tracks Back Mounted (*)

B

B

FRONT SIDE OF THE UNIT

Space reserved for slide bar and bottom seal/brushpile on top, clear of the opening for maximum view.

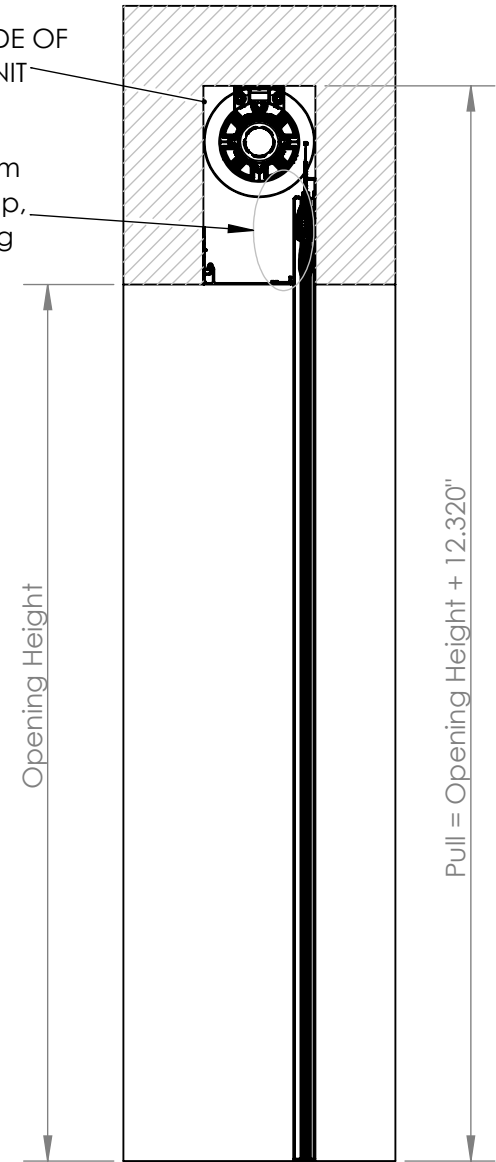
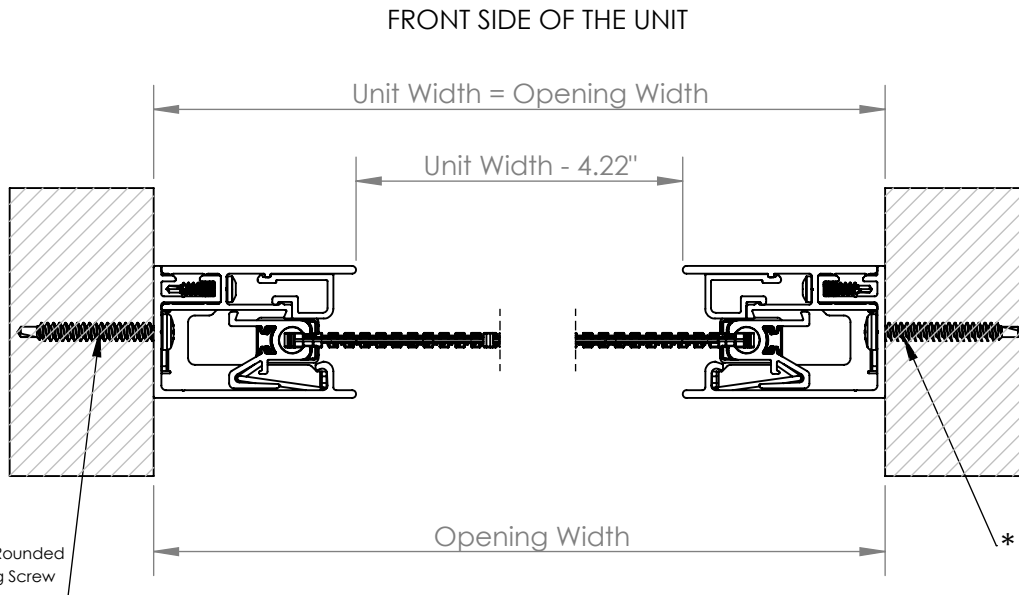

A

A

Note:

- Screen unit height can be reduced by cutting the tracks on site.
- Screen unit width is fixed and must be accurate when ordering.

PROPRIETARY AND CONFIDENTIAL

THE INFORMATION CONTAINED IN THIS DRAWING IS THE SOLE PROPERTY OF PHANTOM SCREENS. REPRODUCTION IN PART OR AS A WHOLE WITHOUT THE WRITTEN PERMISSION OF PHANTOM SCREENS IS PROHIBITED.



UNLESS OTHERWISE SPECIFIED:

DIMENSIONS ARE IN INCHES.
 TOLERANCES:
 FRACTIONAL ± 1/32
 ANGULAR ± 2
 TWO PLACE DECIMAL ± .013"
 THREE PLACE DECIMAL ± .005"

STANDARD TOLERANCES APPLY UNLESS OTHERWISE SPECIFIED

INTERPRET GEOMETRIC TOLERANCING PER: ASME Y14.5
 THIRD ANGLE PROJECTION

MATERIAL

ASSY

DRAWN	SA	2025-12-15
CHECKED	PP	2025-12-15
ENG APPR.	PP	2025-12-15
MFG APPR.		
Q.A.		

TITLE: Mz2.0, 5" Recessed Roller, Sure Fit Track

SIZE	DWG. NO.	REV
A	EPN450	5

SCALE: 1:12	WEIGHT:	SHEET 7 OF 16
-------------	---------	---------------

2

1

2

1

Motorized Retractable Screen

5" Recessed Roller with Sure Fit Track

Tracks In-Jamb and Surface Positioned Tracks Back (*) and Side (**) Mounted

B

B

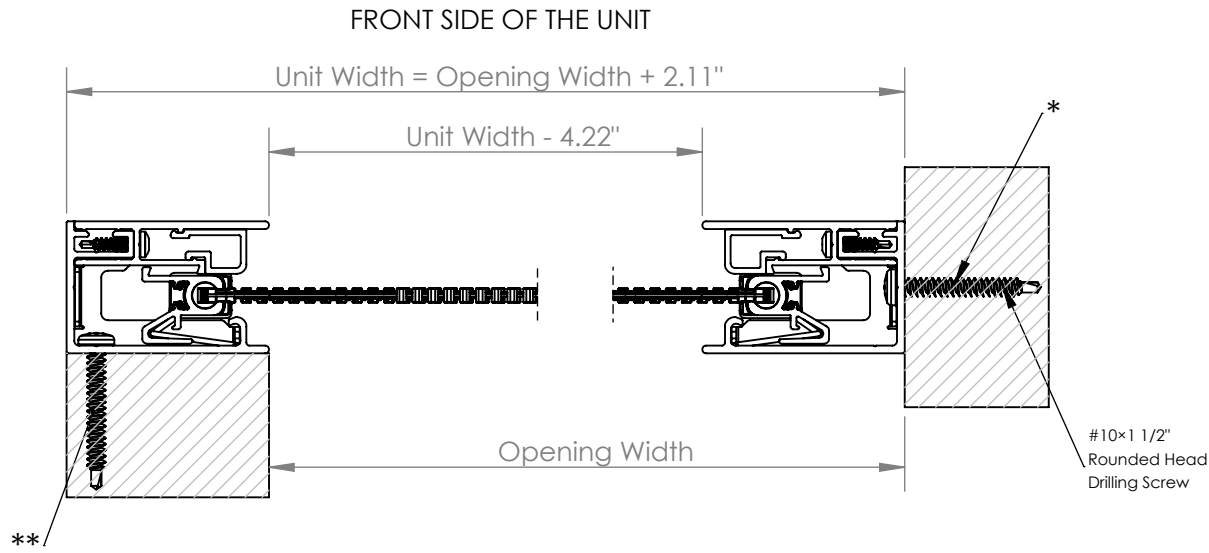

FRONT SIDE OF THE UNIT

Space reserved for slide bar and bottom seal/brushpile on top, clear of the opening for maximum view.

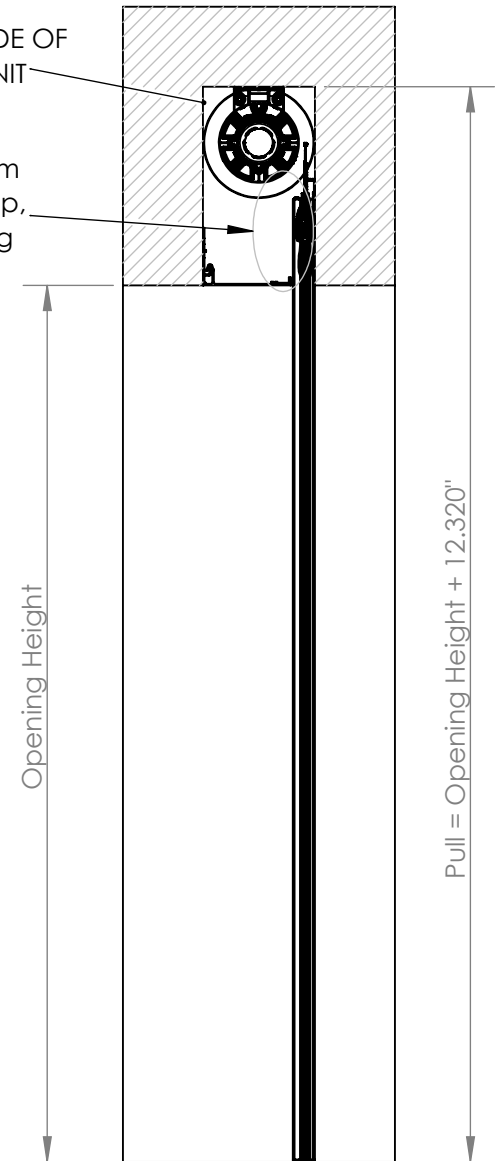

A

A

Note:

- Screen unit height can be reduced by cutting the tracks on site.
- Screen unit width is fixed and must be accurate when ordering.

PROPRIETARY AND CONFIDENTIAL

THE INFORMATION CONTAINED IN THIS DRAWING IS THE SOLE PROPERTY OF PHANTOM SCREENS. REPRODUCTION IN PART OR AS A WHOLE WITHOUT THE WRITTEN PERMISSION OF PHANTOM SCREENS IS PROHIBITED.



UNLESS OTHERWISE SPECIFIED:

DIMENSIONS ARE IN INCHES.
 TOLERANCES:
 FRACTIONAL ± 1/32
 ANGULAR ± 2
 TWO PLACE DECIMAL ± .013"
 THREE PLACE DECIMAL ± .005"

STANDARD TOLERANCES APPLY UNLESS OTHERWISE SPECIFIED

INTERPRET GEOMETRIC TOLERANCING PER: ASME Y14.5
 THIRD ANGLE PROJECTION

MATERIAL

ASSY

DRAWN	SA	2025-12-15
CHECKED	PP	2025-12-15
ENG APPR.	PP	2025-12-15
MFG APPR.		
Q.A.		

TITLE: Mz2.0, 5" Recessed Roller, Sure Fit Track

SIZE	DWG. NO.	REV
A	EPN450	5
SCALE: 1:12	WEIGHT:	SHEET 8 OF 16

2

1

2

1

Motorized Retractable Screen
5" Recessed Roller with Sure Fit Track
U-Guard Used for Adjustment on Unparallel Posts
Tracks In-Jamb Positioned
Tracks Back Mounted (*)

B

B

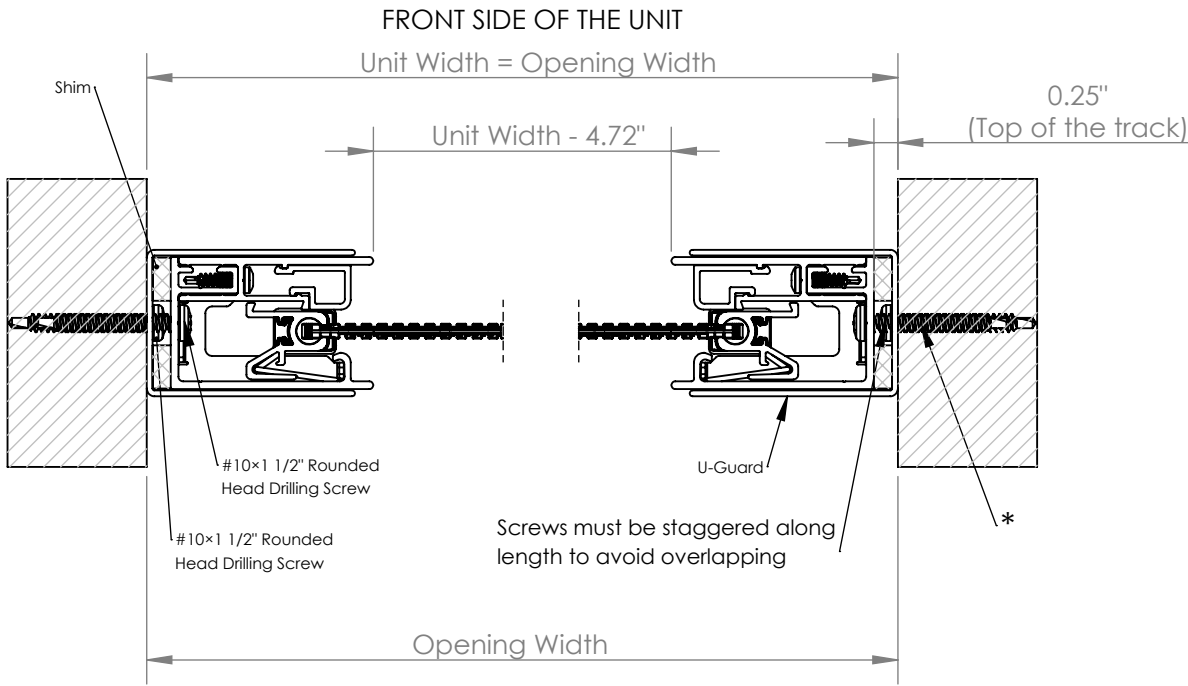

FRONT SIDE OF THE UNIT

Space reserved for slide bar and bottom seal/brushpile on top, clear of the opening for maximum view.

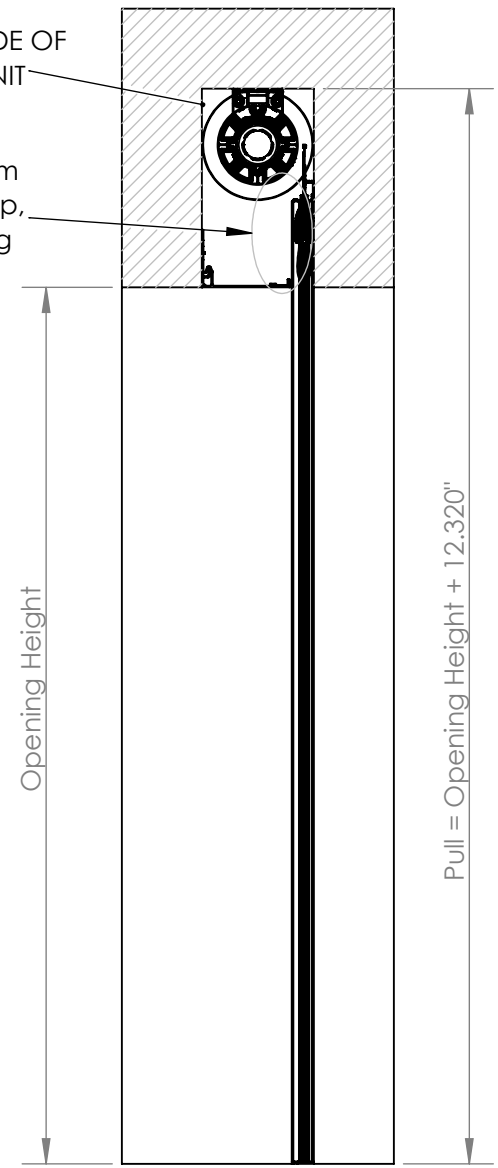

A

A

- Note:**
- Screen unit height can be reduced by cutting the tracks on site.
 - Screen unit width is fixed and must be accurate when ordering.

PROPRIETARY AND CONFIDENTIAL THE INFORMATION CONTAINED IN THIS DRAWING IS THE SOLE PROPERTY OF PHANTOM SCREENS. REPRODUCTION IN PART OR AS A WHOLE WITHOUT THE WRITTEN PERMISSION OF PHANTOM SCREENS IS PROHIBITED.		UNLESS OTHERWISE SPECIFIED: DIMENSIONS ARE IN INCHES. FRACTIONAL ± 1/32 ANGULAR ± 2 TWO PLACE DECIMAL ± .013" THREE PLACE DECIMAL ± .005"		STANDARD TOLERANCES APPLY UNLESS OTHERWISE SPECIFIED INTERPRET GEOMETRIC TOLERANCING PER: ASME Y14.5 THIRD ANGLE PROJECTION		DRAWN SA 2025-12-15 CHECKED PP 2025-12-15 ENG APPR. PP 2025-12-15 MFG APPR. Q.A.		TITLE: Mz2.0, 5" Recessed Roller, Sure Fit Track		
		MATERIAL ASSY		SIZE A		DWG. NO. EPN450		REV 5		
				SCALE: 1:12		WEIGHT:		SHEET 9 OF 16		

2

1

Motorized Retractable Screen

5" Recessed Roller with Sure Fit Track

U-Guard Used for Adjustment on Unparallel Posts

Tracks In-Jamb Positioned

Tracks Side Mounted (*)

B

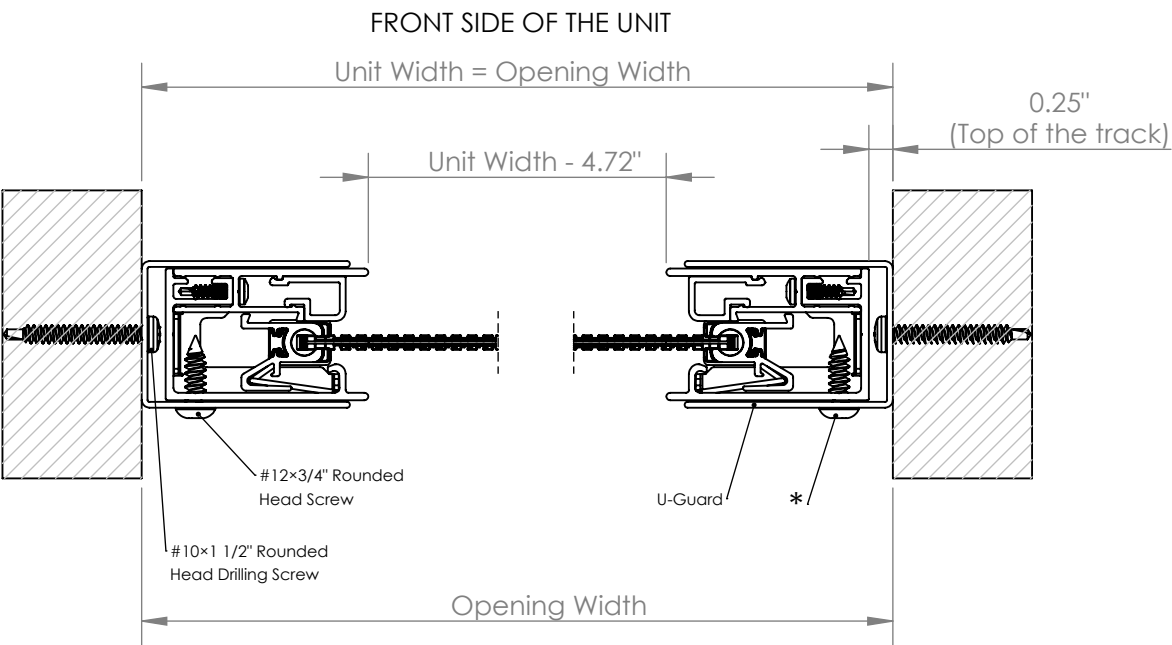

FRONT SIDE OF THE UNIT

Space reserved for side bar and bottom seal/brushpile on top, clear of the opening for maximum view.

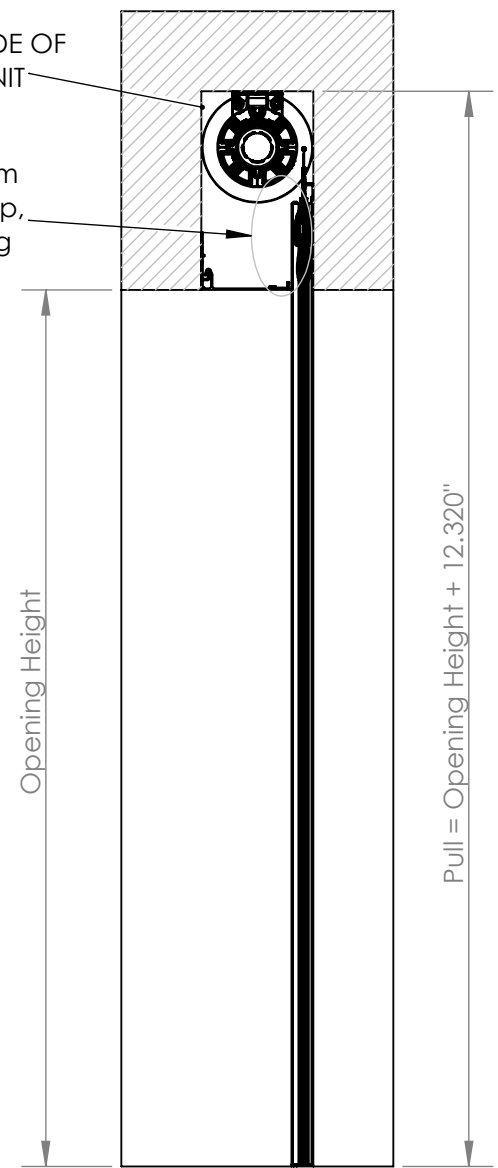

B

A

- Note:**
- Screen unit height can be reduced by cutting the tracks on site.
 - Screen unit width is fixed and must be accurate when ordering.

A

PROPRIETARY AND CONFIDENTIAL		UNLESS OTHERWISE SPECIFIED:		STANDARD TOLERANCES APPLY UNLESS OTHERWISE SPECIFIED		DRAWN SA 2025-12-15		TITLE: Mz2.0, 5" Recessed Roller, Sure Fit Track				
THE INFORMATION CONTAINED IN THIS DRAWING IS THE SOLE PROPERTY OF PHANTOM SCREENS. REPRODUCTION IN PART OR AS A WHOLE WITHOUT THE WRITTEN PERMISSION OF PHANTOM SCREENS IS PROHIBITED.		DIMENSIONS ARE IN INCHES. TOLERANCES: FRACTIONAL ± 1/32 ANGULAR ± 2 TWO PLACE DECIMAL ± .013" THREE PLACE DECIMAL ± .005"		INTERPRET GEOMETRIC TOLERANCING PER: ASME Y14.5 THIRD ANGLE PROJECTION		CHECKED PP 2025-12-15		SIZE A		DWG. NO. EPN450		REV 5
		MATERIAL ASSY		MFG APPR.		Q.A.		SCALE: 1:12		WEIGHT:		SHEET 10 OF 16

Motorized Retractable Screen

5" Recessed Roller with Sure Fit Track

Tracks Recessed-Mounted

B

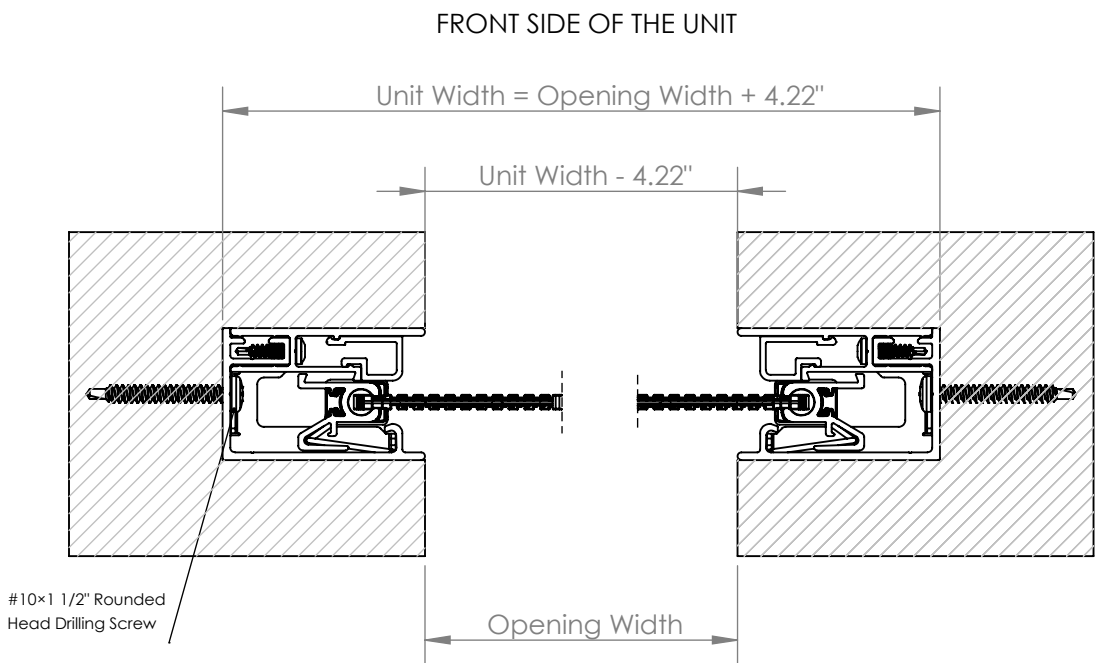

1

FRONT SIDE OF THE UNIT

Space reserved for slide bar and bottom seal/brushpile on top, clear of the opening for maximum view.

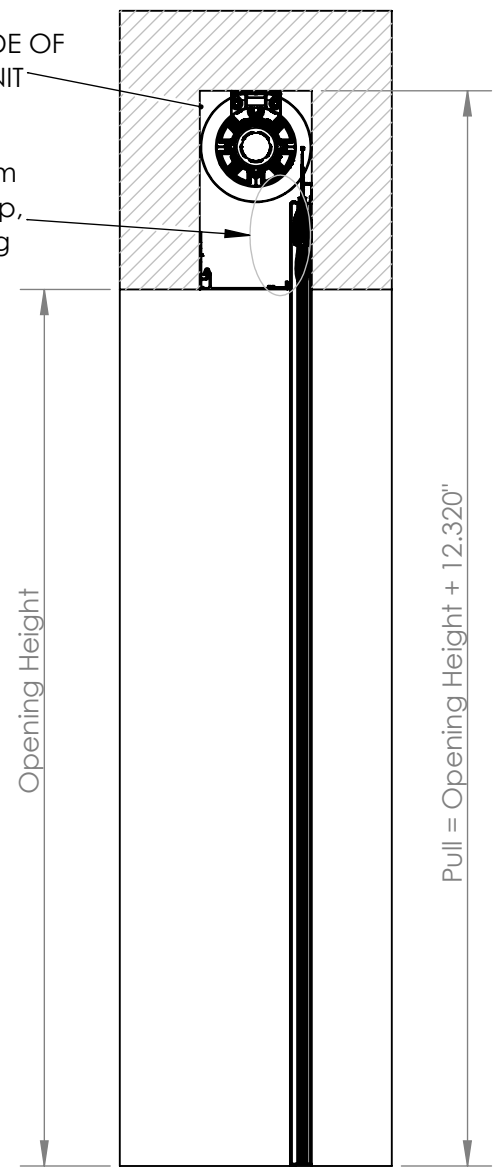

B

A

- Note:**
- Screen unit height can be reduced by cutting the tracks on site.
 - Screen unit width is fixed and must be accurate when ordering.

A

PROPRIETARY AND CONFIDENTIAL THE INFORMATION CONTAINED IN THIS DRAWING IS THE SOLE PROPERTY OF PHANTOM SCREENS. REPRODUCTION IN PART OR AS A WHOLE WITHOUT THE WRITTEN PERMISSION OF PHANTOM SCREENS IS PROHIBITED.		UNLESS OTHERWISE SPECIFIED: DIMENSIONS ARE IN INCHES. FRACTIONAL ± 1/32 ANGULAR ± 2 TWO PLACE DECIMAL ± .013" THREE PLACE DECIMAL ± .005"		STANDARD TOLERANCES APPLY UNLESS OTHERWISE SPECIFIED INTERPRET GEOMETRIC TOLERANCING PER: ASME Y14.5 THIRD ANGLE PROJECTION		DRAWN SA 2025-12-15 CHECKED PP 2025-12-15 ENG APPR. PP 2025-12-15 MFG APPR. Q.A.		TITLE: Mz2.0, 5" Recessed Roller, Sure Fit Track		
		MATERIAL ASSY		SIZE A		DWG. NO. EPN450		REV 5		
				SCALE: 1:12		WEIGHT:		SHEET 11 OF 16		

2

1

Motorized Retractable Screen

5" Recessed Roller with Sure Fit Track

Stucco Build-Up Post with U-Guard

(Build-Up Procedure on Page 12 and 13)

Tracks Recessed-Mounted

B

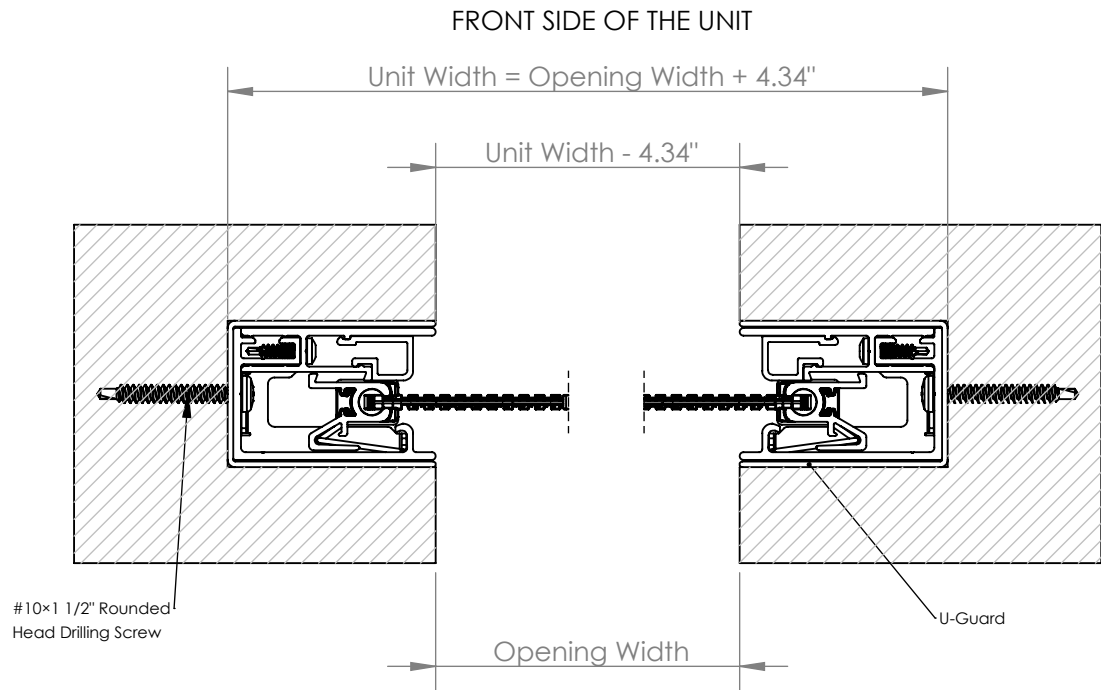

FRONT SIDE OF THE UNIT

Space reserved for slide bar and bottom seal/brushpile on top, clear of the opening for maximum view.

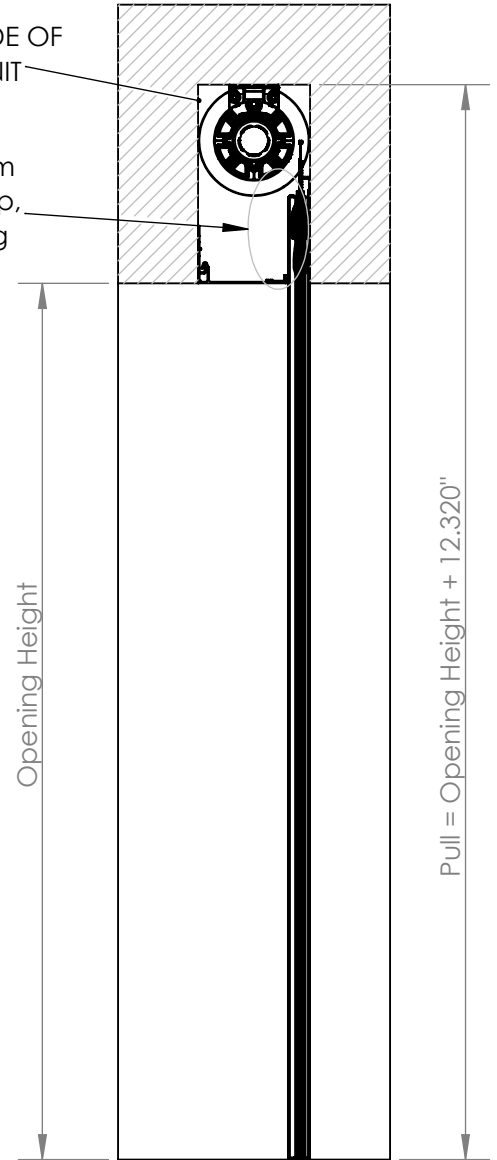

B

A

Note:

- Screen unit height can be reduced by cutting the tracks on site.
- Screen unit width is fixed and must be accurate when ordering.

A

PROPRIETARY AND CONFIDENTIAL THE INFORMATION CONTAINED IN THIS DRAWING IS THE SOLE PROPERTY OF PHANTOM SCREENS. REPRODUCTION IN PART OR AS A WHOLE WITHOUT THE WRITTEN PERMISSION OF PHANTOM SCREENS IS PROHIBITED.		UNLESS OTHERWISE SPECIFIED: DIMENSIONS ARE IN INCHES. TOLERANCES: FRACTIONAL $\pm 1/32$ ANGULAR ± 2 TWO PLACE DECIMAL $\pm .013$ " THREE PLACE DECIMAL $\pm .005$ "		STANDARD TOLERANCES APPLY UNLESS OTHERWISE SPECIFIED INTERPRET GEOMETRIC TOLERANCING PER: ASME Y14.5 THIRD ANGLE PROJECTION		DRAWN SA 2025-12-15 CHECKED PP 2025-12-15 ENG APPR. PP 2025-12-15 MFG APPR. Q.A.		TITLE: Mz2.0, 5" Recessed Roller, Sure Fit Track		
		MATERIAL ASSY		SIZE A		DWG. NO. EPN450		REV 5		
				SCALE: 1:12		WEIGHT:		SHEET 12 OF 16		

2

1

Motorized Retractable Screen
5" Recessed Roller with Sure Fit Track
Stucco Build-Up Post with U-Guard
Tracks Recessed-Mounted

B

B

Track Installation Procedure with Stucco Build-up Posts

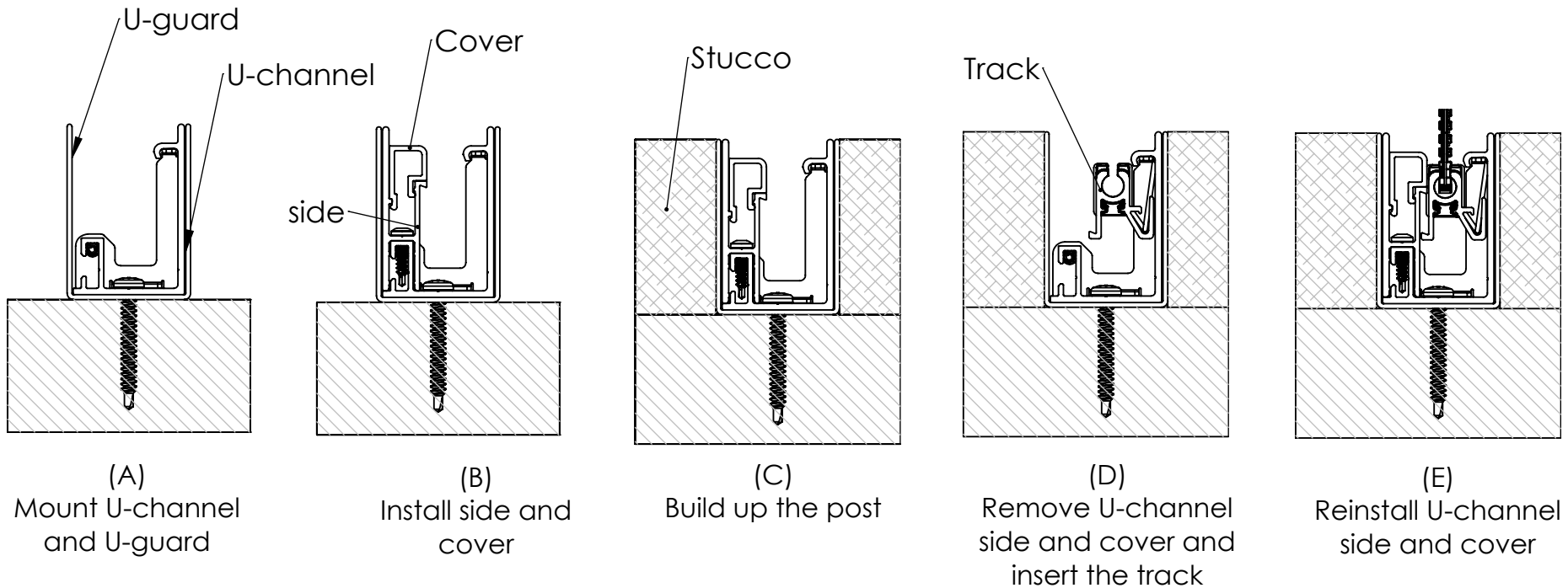

A

A

PROPRIETARY AND CONFIDENTIAL

THE INFORMATION CONTAINED IN THIS DRAWING IS THE SOLE PROPERTY OF PHANTOM SCREENS. REPRODUCTION IN PART OR AS A WHOLE WITHOUT THE WRITTEN PERMISSION OF PHANTOM SCREENS IS PROHIBITED.



PHANTOM
SCREENS

UNLESS OTHERWISE SPECIFIED:
 DIMENSIONS ARE IN INCHES.
 TOLERANCES:
 FRACTIONAL ± 1/32
 ANGULAR ± 2
 TWO PLACE DECIMAL ± .013"
 THREE PLACE DECIMAL ± .005"

STANDARD TOLERANCES APPLY UNLESS OTHERWISE SPECIFIED

INTERPRET GEOMETRIC TOLERANCING PER: ASME Y14.5
 THIRD ANGLE PROJECTION

MATERIAL
 ASSY

DRAWN	SA	2025-12-15
CHECKED	PP	2025-12-15
ENG APPR.	PP	2025-12-15
MFG APPR.		
Q.A.		

TITLE: Mz2.0, 5" Recessed Roller, Sure Fit Track		
SIZE	DWG. NO.	REV
A	EPN450	5
SCALE: 1:12	WEIGHT:	SHEET 13 OF 16

Motorized Retractable Screen

5" Recessed Roller with Sure Fit Track

Stucco Build-Up Post with U-Guard

Tracks Surface-Mounted

B

B

Track Installation Procedure with Stucco Build-up Posts

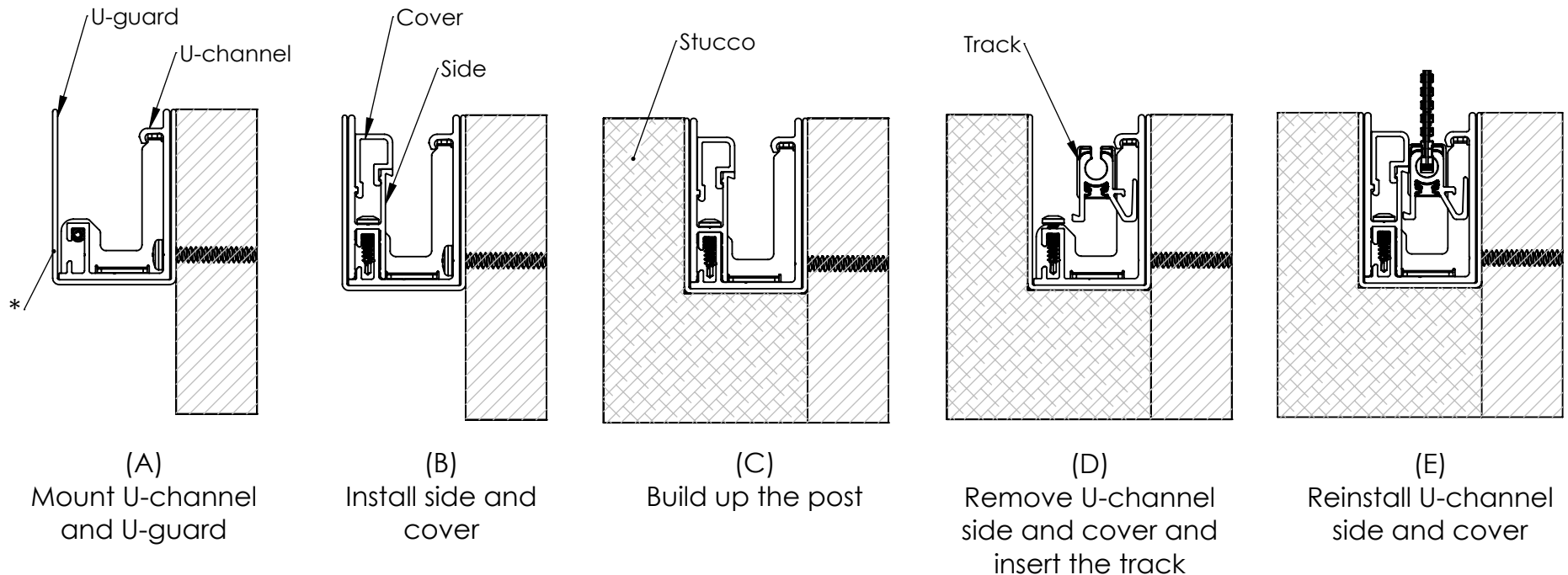

A

A

* Predrill the U-guard to align with existing predrilled holes on the U-channel main. Mount both to the surface with screws. Cover the U-guard predrilled holes with tape to prevent stucco from entering the U-guard.

PROPRIETARY AND CONFIDENTIAL THE INFORMATION CONTAINED IN THIS DRAWING IS THE SOLE PROPERTY OF PHANTOM SCREENS. REPRODUCTION IN PART OR AS A WHOLE WITHOUT THE WRITTEN PERMISSION OF PHANTOM SCREENS IS PROHIBITED.		UNLESS OTHERWISE SPECIFIED: DIMENSIONS ARE IN INCHES. FRACTIONAL $\pm 1/32$ ANGULAR ± 2 TWO PLACE DECIMAL $\pm .013$ " THREE PLACE DECIMAL $\pm .005$ "		STANDARD TOLERANCES APPLY UNLESS OTHERWISE SPECIFIED INTERPRET GEOMETRIC TOLERANCING PER: ASME Y14.5 THIRD ANGLE PROJECTION		DRAWN SA 2025-12-15 CHECKED PP 2025-12-15 ENG APPR. PP 2025-12-15 MFG APPR. Q.A.		TITLE: Mz2.0, 5" Recessed Roller, Sure Fit Track SIZE A DWG. NO. EPN450 REV 5 SCALE: 1:12 WEIGHT: SHEET 14 OF 16		
		MATERIAL ASSY								

Motorized Retractable Screen
5" Recessed Roller with Sure Fit Track
L-Flap Used for Adjustment on Unparallel Posts
Tracks In-Jamb Positioned
Tracks Side Mounted (*)
L-Flap Mounted behind the Track ()**

B

B

FRONT SIDE OF THE UNIT

Space reserved for slide bar and bottom seal/brushpile on top, clear of the opening for maximum view.

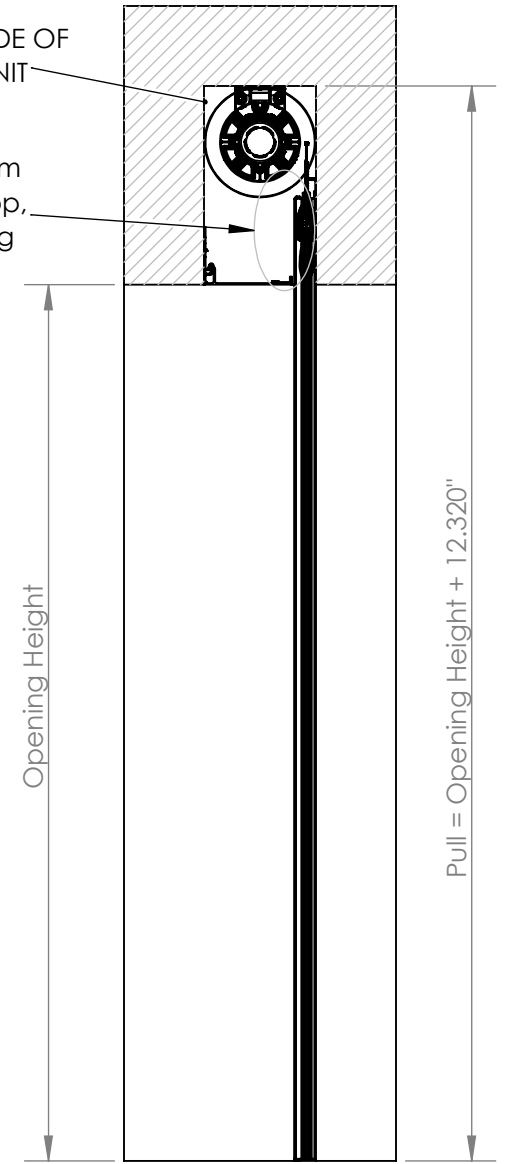
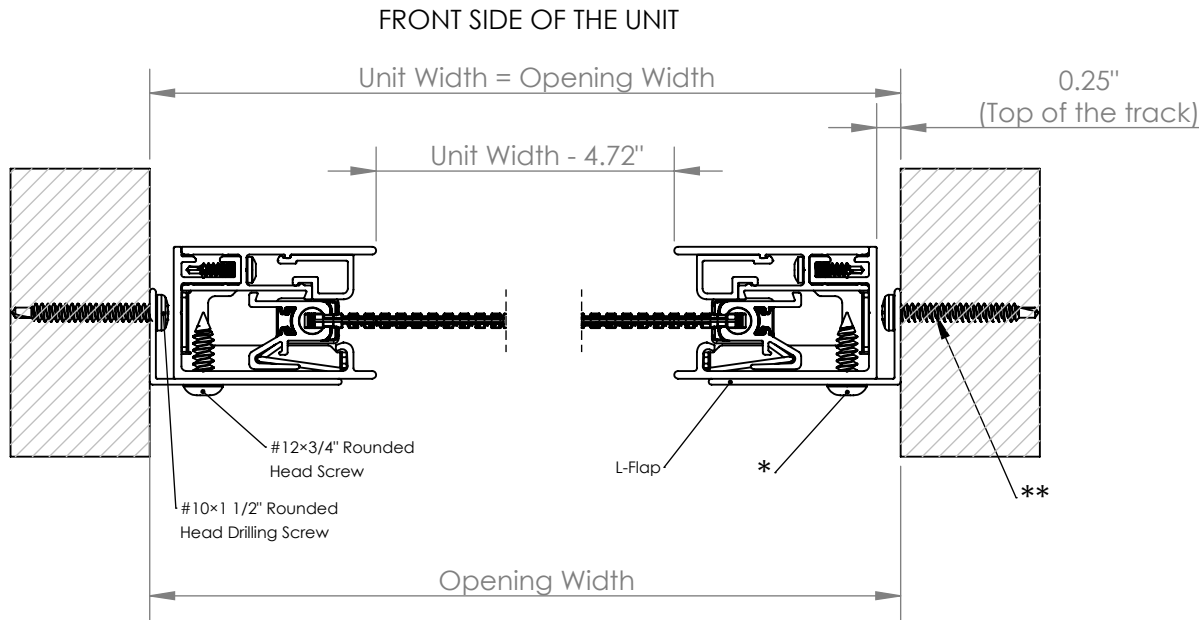

A

A

Note:

- Screen unit height can be reduced by cutting the tracks on site.
- Screen unit width is fixed and must be accurate when ordering.

PROPRIETARY AND CONFIDENTIAL		UNLESS OTHERWISE SPECIFIED:		STANDARD TOLERANCES APPLY UNLESS OTHERWISE SPECIFIED		DRAWN SA 2025-12-15		TITLE: Mz2.0, 5" Recessed Roller, Sure Fit Track			
		DIMENSIONS ARE IN INCHES. TOLERANCES: FRACTIONAL ± 1/32 ANGULAR ± 2 TWO PLACE DECIMAL ± .013" THREE PLACE DECIMAL ± .005"		INTERPRET GEOMETRIC TOLERANCING PER: ASME Y14.5 THIRD ANGLE PROJECTION		CHECKED PP 2025-12-15		SIZE A		DWG. NO. EPN450	REV 5
						MATERIAL ASSY		ENG APPR. PP 2025-12-15		MFG APPR.	
						Q.A.					

Motorized Retractable Screen
5" Recessed Roller with Sure Fit Track
L-Flap Used for Adjustment on Unparallel Posts
Tracks In-Jamb Positioned
Tracks Side Mounted (*)
L-Flap Mounted on the Side of the Track ()**

B

B

FRONT SIDE OF THE UNIT
 Space reserved for slide bar and bottom seal/brushpile on top, clear of the opening for maximum view.

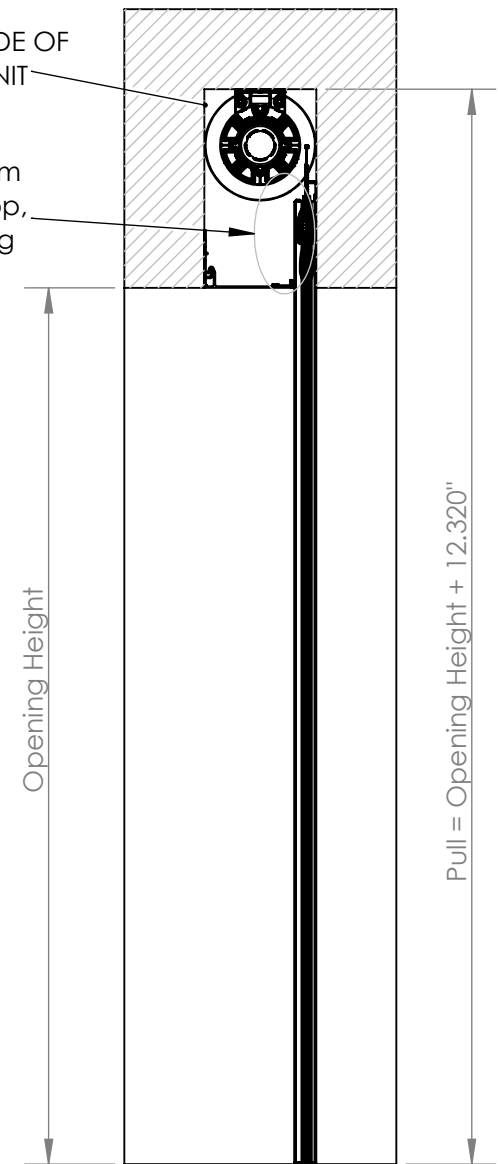
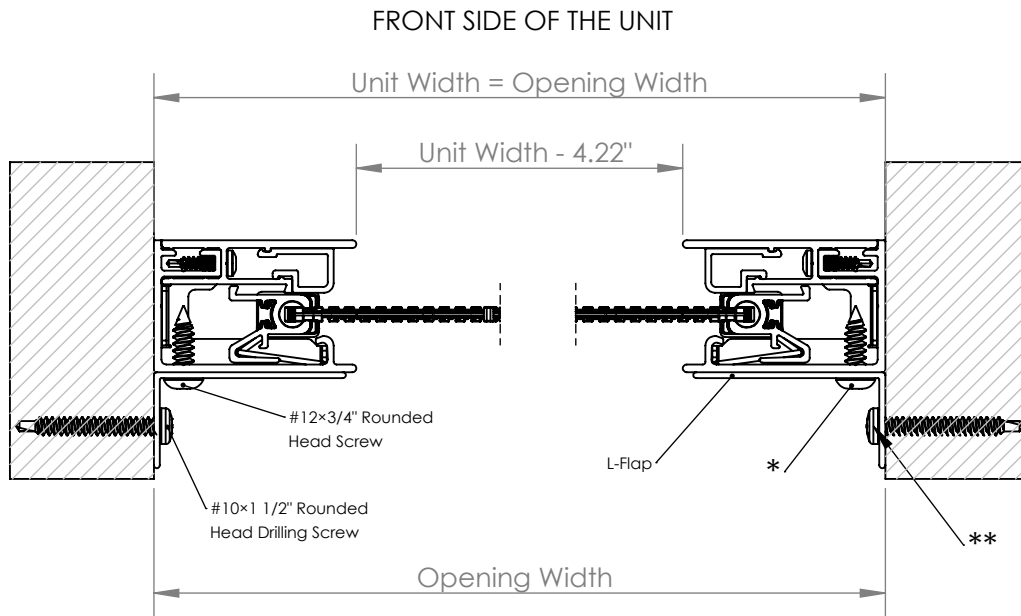

A

A

- Note:**
- Screen unit height can be reduced by cutting the tracks on site.
 - Screen unit width is fixed and must be accurate when ordering.

PROPRIETARY AND CONFIDENTIAL THE INFORMATION CONTAINED IN THIS DRAWING IS THE SOLE PROPERTY OF PHANTOM SCREENS. REPRODUCTION IN PART OR AS A WHOLE WITHOUT THE WRITTEN PERMISSION OF PHANTOM SCREENS IS PROHIBITED.		UNLESS OTHERWISE SPECIFIED: DIMENSIONS ARE IN INCHES. TOLERANCES: FRACTIONAL ± 1/32 ANGULAR ± 2 TWO PLACE DECIMAL ± .013" THREE PLACE DECIMAL ± .005"		STANDARD TOLERANCES APPLY UNLESS OTHERWISE SPECIFIED INTERPRET GEOMETRIC TOLERANCING PER: ASME Y14.5 THIRD ANGLE PROJECTION		DRAWN SA 2025-12-15 CHECKED PP 2025-12-15 ENG APPR. PP 2025-12-15 MFG APPR. Q.A.		TITLE: Mz2.0, 5" Recessed Roller, Sure Fit Track SIZE A DWG. NO. EPN450 REV 5 SCALE: 1:12 WEIGHT: SHEET 16 OF 16		
		MATERIAL ASSY								